



Operating manual
Electropneumatic Positioner ARCAPRO® - Version
without/with HART-Communication
Series 827A.E/X

Original instructions

© ARCA Regler GmbH. All rights reserved.

Cover picture background: Freepik.com

Table of Contents

| | | |
|----------|--|-----------|
| 1 | General data | 5 |
| 1.1 | Validity of the manual | 5 |
| 1.2 | Contact details..... | 5 |
| 1.3 | Other applicable documents..... | 5 |
| 1.4 | Place of storage of the manual..... | 5 |
| 2 | Safety | 6 |
| 2.1 | Introduction..... | 6 |
| 2.2 | General safety information | 6 |
| 2.3 | Explanation of symbols and notices | 6 |
| 2.4 | Warning symbols on the device | 7 |
| 2.5 | Intended use..... | 7 |
| 2.6 | Improper modifications to the device..... | 8 |
| 2.7 | Qualified Personnel | 8 |
| 2.8 | Liability disclaimer | 8 |
| 2.9 | Laws and regulations | 8 |
| 2.10 | Conformity to European directives | 9 |
| 2.11 | Use in potentially explosive areas | 9 |
| 3 | Transport, storage and packaging | 11 |
| 3.1 | Transport | 11 |
| 3.2 | Storage | 11 |
| 3.3 | Packaging..... | 11 |
| 4 | Type plate | 12 |
| 5 | Type key | 13 |
| 6 | Description | 15 |
| 6.1 | Function..... | 15 |
| 6.2 | Construction | 15 |
| 6.3 | Device Components | 17 |
| 6.3.1 | Motherboard | 17 |
| 6.3.2 | Electrical Connections..... | 17 |
| 6.3.3 | Pneumatic Connections | 18 |
| 6.3.4 | Purging Air Switch | 19 |
| 6.3.5 | Restrictors | 20 |
| 7 | Assembly | 21 |
| 7.1 | Safety instructions for assembly..... | 21 |
| 7.2 | Mounting a linear actuator | 22 |
| 7.2.1 | Mounting with mounting kit for "Integrated Fitting Linear Actuator"..... | 22 |
| 7.2.2 | Mounting with mounting kit "Linear actuator IEC 534" | 24 |
| 7.3 | Mounting with mounting kit "Rotary actuator VDI/VDE 3845" | 28 |
| 7.4 | Use of positioners in humid environment | 31 |

| | | |
|-----------|---|-----------|
| 7.5 | Positioners that are exposed to high acceleration forces or strong vibrations | 32 |
| 7.5.1 | Slip clutch | 33 |
| 7.5.2 | Transmission ratio selector | 33 |
| 8 | Electrical connection | 35 |
| 8.1 | Electrical connection of basic device..... | 37 |
| 8.2 | Electrical connection options..... | 39 |
| 8.3 | Optional version M12 plug..... | 43 |
| 9 | Pneumatic connection | 45 |
| 10 | Commissioning | 46 |
| 10.1 | Preparation for commissioning of linear actuators | 48 |
| 10.1.1 | Automatic initialisation of linear actuators | 48 |
| 10.1.2 | Manual initialisation of linear actuators | 50 |
| 10.2 | Preparation for commissioning of rotary actuators..... | 52 |
| 10.2.1 | Automatic initialisation of rotary actuators..... | 53 |
| 10.2.2 | Manual initialisation of rotary actuators..... | 54 |
| 10.3 | Copying Initialisation Data (Positioner Exchange) | 55 |
| 11 | Parameter overview | 57 |
| 11.1 | Parameters 1 to 5..... | 57 |
| 11.2 | Parameters 6 to 52..... | 57 |
| 11.3 | Parameters A to P | 60 |
| 12 | Service and maintenance | 63 |
| 13 | Technical Data | 65 |
| 14 | Fault removal | 71 |
| 15 | Disposal and recycling | 74 |

1 General data

This operating manual contains instructions that enable the product to be safely and properly installed, put into operation and maintained.

The target group for this operating manual is exclusively specially trained and authorised technical personnel.

Please contact the manufacturer if you encounter problems that cannot be solved with the aid of this operating manual.

The product is subject to technical changes at any time.

1.1 Validity of the manual

This operating manual applies to the product in the version described in the device pass.

1.2 Contact details

Further information about the product can be obtained from:

Manufacturer's address

ARCA Regler GmbH
Kempener Str. 18

1.3 Other applicable documents

The product can be delivered as part of an actuator and equipped with additional components that are described in their own operating manuals. The instructions as well as the warning and safety information contained therein must also be observed.

Furthermore, the following documents apply in addition to this operating manual.

- Device pass
- Installation drawing

1.4 Place of storage of the manual

The operating manual and all other applicable documents are part of the product. They must be kept in the immediate vicinity of the product and must be accessible to the personnel at all times.

2 Safety

2.1 Introduction

This manual contains all the information you need for the connection and commissioning of the device.

It is addressed to people who mechanically mount, electrically connect, parameterise and commission the device, as well as service and maintenance technicians.

This manual applies to devices from firmware version 5.00.00 in both non-intrinsically and intrinsically safe versions.

We hereby provide notice that the contents of this operating manual do not form part of a former or existing agreement, acceptance or of a relationship in law, nor do they modify any such agreement. All obligations arise out of the particular sales contract, and this also contains the whole of any applicable warranty clauses. The terms of this contractual warranty are neither extended nor restricted by any material in this document.

The contents reflect the technical level at the time of printing.

We reserve the right to make technical changes in the course of further



WARNING

Use of a damaged or incomplete device

Risk of explosion!

- ▶ Do not use damaged or incomplete devices.

2.2 General safety information

Requirement for safe use

This equipment has been supplied from the factory in a totally safe condition. To maintain this condition and to ensure safe operation of the device, follow these instructions and observe all safety-relevant information.

Pay attention to the notices and symbols on the device. Do not remove any notices or symbols from the device. Keep the notices and symbols in a fully legible condition at all times.

2.3 Explanation of symbols and notices

This documentation contains notes that you must observe for your own personal safety and for the avoidance of damage to property. Notes concerning personal safety are highlighted by a warning triangle; notes concerning only damage to property are not marked by a warning triangle. Depending on the danger level, the warning notes are shown in decreasing order of severity as follows:



DANGER

means that death or serious injuries will occur if the corresponding preventive measures are not taken.



WARNING

means that death or serious injuries can occur if the corresponding preventive measures are not taken.



CAUTION

with a warning triangle means that slight injury and/or damage to property can occur if the corresponding preventive measures are not taken.



NOTICE

indicates an important item of information about the product itself or how the product should be handled, to which special attention should be paid.

CAUTION



without a warning triangle means that damage to property can occur if the corresponding preventive measures are not taken.

ATTENTION

indicates that an undesirable event or condition can occur if the corresponding instructions are not observed.

If several danger levels occur, the warning note for the respectively highest level will always be used. If a warning note with a warning triangle warns against personal injury, a warning against damage to property may be included in the same warning note.

2.4 Warning symbols on the device

| Symbol | Explanation of the warning symbols on the device |
|---|--|
|  | Observe the operating manual |
|  | Protect the device against shocks (otherwise the protection class is not guaranteed) |

2.5 Intended use

Observe the following:



WARNING

ARCA positioners may be used only for the applications specified in the associated technical documentation. Proper transport, storage, erection, assembly, installation, commissioning, operation and maintenance are required for trouble-free and safe operation. The permissible environmental conditions must be maintained. Notices in the associated documentation must be observed.



2.6 Improper modifications to the device

WARNING

Modification to the device

Modifications and repairs to the device, in particular in potentially explosive areas, can be dangerous for personnel, the plant and the environment!

- ▶ Modify or repair the device only as described in the instructions for the device. The manufacturer's warranty and the product approvals are rendered null and void if this is ignored.

2.7 Qualified Personnel

The device may be set up and operated only in conjunction with this documentation. Startup and operation may be performed only by **qualified personnel**. Qualified personnel within the meaning of the safety instructions in this documentation are persons who are authorised to commission, earth and mark devices, systems and circuits according to the safety standards.

Qualified persons are those who are familiar with the erection, assembly, startup and operation of the product. These persons possess the following qualifications:

- They are authorised and have been trained or instructed to operate and maintain devices and systems in accordance with the safety standards for electrical circuits, high pressures and aggressive and/or hazardous media.
- In the case of devices with explosion protection: they are authorised and have been trained or instructed to carry out work on electrical circuits for plants that are at risk from explosions.
- They have been trained or instructed in the care and use of appropriate safety equipment in accordance with safety standards.

2.8 Liability disclaimer

We have checked the contents of this manual for correspondence to the hardware and software described. Nevertheless, deviations cannot be ruled out; therefore we cannot give any guarantee for full correspondence. The details are checked regularly and any necessary corrections will be included in subsequent editions.

2.9 Laws and regulations

The test certificates, regulations and laws applicable to your country must be observed for the connection, assembly and operation.

These are, for example:

- IEC 60079-14 (international)
- EN 60079-14 (EC)
- Operational safety ordinance

2.10 Conformity to European directives

The CE mark on the device indicates its conformity to the following European directives:

| | |
|--------------------|--|
| 2014/30/EU EMC | Directive of the European Parliament and of the Council on the harmonisation of the Laws of the Member States relating to electromagnetic compatibility. |
| 2014/34/EU ATEX | Directive of the European Parliament and of the Council on the harmonisation of the Laws of the Member States relating to equipment and protection systems intended for use in potentially explosive atmospheres. |
| 2014/35/EU LVD | Directive of the European Parliament and of the Council on the harmonisation of the Laws of the Member States relating to the making available of electrical equipment designed for the use within certain voltage limits. |

The applied standards can be found in the EU Declaration of Conformity for the device.

2.11 Use in potentially explosive areas



WARNING

Unsuitable device for potentially explosive areas

Risk of explosion!

- ▶ Use only devices that are approved for use in Ex-zones and are marked accordingly.
- ▶ Make sure that the device is suitable for the area of use.



WARNING

Loss of safety of the device in the ignition protection class Intrinsic Safety "Ex i"

If the device has already been operated on non-intrinsically safe circuits or with a higher operating voltage, the safety of the device for use in potentially explosive areas is no longer guaranteed. There is a danger of explosion!

- ▶ Connect the device in the ignition protection class Intrinsic Safety exclusively to an intrinsically safe electrical circuit.
- ▶ Observe the electrical data in the certificate.



⚠ WARNING

Impermissible accessories and impermissible spare parts

Danger of explosion in potentially explosive areas or damage to the device!

- ▶ Use exclusively original accessories and original spare parts.
- ▶ Observe all relevant installation and safety instructions described in the manuals for the device, accessories and spare parts.



⚠ WARNING

Open cable entry or incorrect cable gland

Danger of explosion in potentially explosive areas or damage to the device!

- ▶ Seal the cable entries for the electrical connections. Use exclusively cable glands or blanking plugs for this that are approved for the respective ignition protection class.



⚠ WARNING

Exceeding the maximum ambient or media temperature

Risk of explosion in potentially explosive areas

The temperature class of the device is no longer valid if the maximum permissible ambient or media temperature is exceeded!

- ▶ Make sure that the maximum permissible ambient or media temperature of the device is not exceeded.



⚠ WARNING

Electrostatic charging of nameplates

The nameplates used on the device can reach a charging capacity of 5 pF.

- ▶ Keep the device and the cables at a distance from strong electromagnetic fields.



⚠ CAUTION

Electrostatically endangered assemblies

The device contains electrostatically endangered assemblies. Electrostatically endangered assemblies can be destroyed by voltages far below the threshold of human perception. These voltages already occur if you touch a component or electrical connection without having electrostatically discharged yourself first. The damage caused to an assembly due to overvoltage is not usually immediately apparent and only becomes noticeable after a lengthy period of operation.

- ▶ Therefore, prevent electrostatic charging.

3 Transport, storage and packaging

3.1 Transport

Transport at a temperature lower than -40 °C or higher than $+80\text{ °C}$ is not permissible.

3.2 Storage



NOTICE

Improper storage!

There is a danger of the product no longer functioning if it is stored improperly.

- ▶ Storage at a temperature lower than -40 °C or higher than $+80\text{ °C}$ is not permissible.
- ▶ It must be stored in roofed-over storage places and that are weather-proof.

Openings are sealed with suitable means to prevent the ingress of dirt. These should be removed by technical personnel at the place of installation.



⚠ CAUTION

Inadequate protection during storage

The packaging offers only limited protection against moisture and infiltration!

- ▶ Provide additional packaging if necessary.

3.3 Packaging

The product is packed in a PE film inside the outer packaging (cardboard box, wooden crate, pallet, lattice box).

If the packaging, in particular the PE film, has been opened, the product must be stored immediately in a heated room.

The product must be packed in weatherproof or seaworthy packaging for transport by ship, rail or truck.

4 Type plate

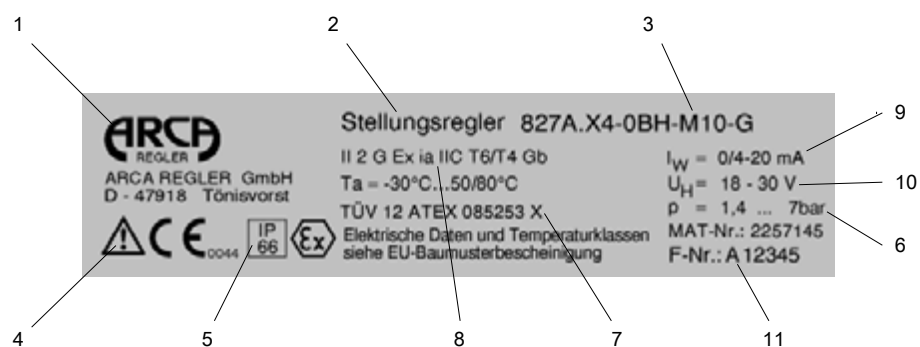

Illustration 1: 827A type plate

| | |
|----|--|
| 1 | Manufacturer |
| 2 | Device name |
| 3 | Type |
| 4 | Observe the operating manual |
| 5 | Protection class |
| 6 | Auxiliary power (air supply) |
| 7 | Approval |
| 8 | ATEX marking for potentially explosive areas |
| 9 | Nominal signal range |
| 10 | Auxiliary energy (voltage) |
| 11 | Fabrication number |

5 Type key

| | | | | | | | | | | | | | | |
|------|-----|-----|---|-----|-----|-----|---|-----|-----|-----|---|------|---|------|
| 827A | E | 2 | - | A | 0 | H | - | M | 1 | 0 | - | G | - | LT |
| . | | | | | | | | | | | | | | |
| [1] | [2] | [3] | - | [4] | [5] | [6] | - | [7] | [8] | [9] | - | [10] | - | [11] |

1. Series

827A.

2. Explosion protection ¹⁾

| | |
|---|---|
| E | not explosion protected |
| X | explosion protected "ia" ^{1) 2)} |

3. Basic device connection

| | |
|---|--------------------------|
| 2 | 2-wire |
| 4 | 2/3/4-wire ³⁾ |

4. Analogue output

| | |
|---|-------------------------|
| 0 | without analogue output |
| A | analog module |

5. Binary output

| | |
|---|----------------------------|
| 0 | without binary output |
| B | Binary module |
| S | Slot-type initiator module |
| K | Contact module |

6. Communication

| | |
|---|-----------------------|
| 0 | without communication |
| H | HART |
| P | PROFIBUS PA |
| F | Foundation Fieldbus |

7. Housing material

| | |
|---|--------------------------------|
| M | Aluminium (single-acting only) |
| E | Stainless steel |

8. Pneumatics

| | |
|---|--|
| 1 | single-acting |
| 2 | double-acting (except aluminium housing) |

9. Mechanical actuator

| | |
|---|--------------------------------------|
| 0 | Standard |
| 2 | without (for external potentiometer) |

10. Connecting thread electrical/pneumatic

| | |
|---|-----------------------------------|
| G | M20x1.5 / G 1/4 |
| N | 1/2" NPT / 1/4" NPT |
| M | M20x1.5 / 1/4" NPT |
| P | 1/2" NPT / G 1/4 |
| Q | M25x1.5 / 1/4" NPT (Ex d only) |
| R | M12 plug for input signal / G 1/4 |

10. Connecting thread electrical/pneumatic

| | |
|---|--------------------------------------|
| S | M12 plug for input signal / 1/4" NPT |
|---|--------------------------------------|

11. Options

| | |
|-----|---|
| FIP | Fail In Place ⁴⁾ |
| LT | - 40 °C ⁴⁾ |
| SA | M12 plug for analogue module |
| SB | M12 plug for binary module |
| SS | M12 plug for slot-type initiator module |
| SW | M12 plug for external displacement sensor |

¹⁾ ATEX approval, other approvals on enquiry

²⁾ with HART communication, 2/3/4-wire only

³⁾ except PROFIBUS PA and Foundation fieldbus

⁴⁾ on enquiry

Example of type designation

827A.E2-A0H-M10-G-LT

827A Positioner - without explosion protection - 2-wire connection - analogue module - without binary output - HART communication, aluminium housing - single-acting - standard mechanical actuator - connecting thread electrical M20x1.5 / pneumatic G 1/4 / - 40 °C

6 Description

6.1 Function

- The electro-pneumatic positioner forms, in combination with an actuator, a control system. The present position of the actuator is acquired by means of a servo-potentiometer, and is fed back as the actual value, x . Setpoint and actual value are shown simultaneously on the digital display.
- The setpoint, w , is defined by a current which is fed, under a two-wire operation, to the positioner, and which is also used to power the positioner. In 3- and 4-wire operation, the power is supplied via a 24 V power input.
- The positioner operates as a predictive five-point controller, whose output magnitude $\pm\Delta y$ is converted to a pulse length modulated signal to operate the control valves.
- These control signals cause changes of pressure in the actuating chamber(s), thus adjusting the actuator until the control error becomes zero.
- After removing the housing cover, the operation (manual mode) and configuration (structuring, initialisation and parameterisation) are done using three buttons and a digital display.
- Normally the basic device has one binary input (BE1). This binary input can be individually configured and used, for example, to block the operating levels.
- In order to be able to use the positioner on a large number of mechanically differing rotary and linear actuators, it has a slip clutch and a switchable transmission.

6.2 Construction

This section describes the mechanical and electrical construction, the device components and the principles of the positioner's operation.

The positioner is used to adjust and regulate pneumatic actuators. The positioner operates electro-pneumatically. Compressed air provides its auxiliary energy.

The positioner can be used, for instance, to regulate valves with:

- a linear actuator (Fig. 2) or
- a VDI/VDE 3845 rotary actuator (Fig. 3)

Linear actuators may be mounted in a number of ways.

- NAMUR or IEC 534
- integrated mounting (ARCA, SAMSON)
- integrated mounting according to VDI/VDE 3847

The positioner can be mounted and operated on all normal actuators.

The device is available for single-acting and double-acting actuators as well as for potentially explosive and non-potentially explosive applications.

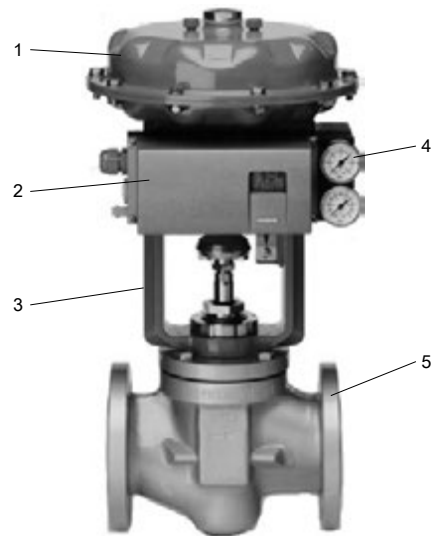

| | |
|---|--|
| 1 | Actuator |
| 2 | Positioner, single-acting in metal housing |
| 3 | Yoke |
| 4 | Manometer block, single-acting |
| 5 | Valve |

Illustration 2: Positioner mounted on a linear actuator (single-acting)



| | |
|---|---|
| 1 | Positioner, double-acting, in stainless steel housing |
| 2 | Rotary actuator |
| 3 | Manometer block, double-acting |

Illustration 3: Positioner mounted on a rotary actuator (double-acting)

6.3 Device Components

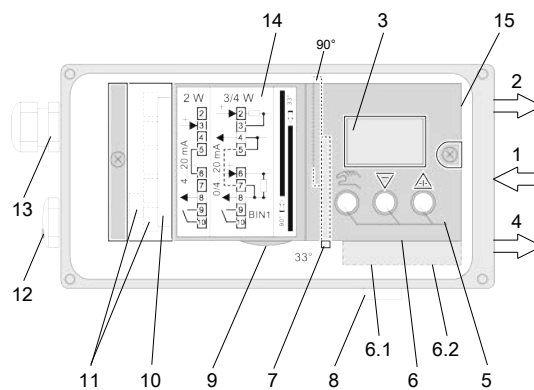

| | |
|-----|--|
| 1 | Supply air input |
| 2 | Output: actuating pressure Y1 |
| 3 | Display |
| 4 | Output: actuating pressure Y2 *) |
| 5 | Operating Buttons |
| 6 | Restrictor Y1 |
| 6.1 | Restrictor Y1 *) |
| 6.2 | Restrictor Y2 *) |
| 7 | Transmission ratio selector |
| 8 | Silencer |
| 9 | Slip clutch adjusting wheel |
| 10 | Basic device connecting terminals |
| 11 | Connecting terminals Option modules |
| 12 | Blinding plug |
| 13 | Cable gland |
| 14 | Clamping plate for cover |
| 15 | Purging air switch |
| * | with double/acting devices |

Illustration 4: Construction

6.3.1 Motherboard

Located on the motherboard are:

- CPU
- Memory
- A/D converter
- Display
- Operating Buttons
- Connecting strips for the connection of the option modules to the motherboard.

6.3.2 Electrical Connections

The connecting terminals of the basic device as well as the analogue, binary and slot-type initiator module are located at the front left-hand edge and offset to each other in a staircase form.

An assembly cover secures the components against being pulled out, and prevents incorrect assembly.

6.3.3 Pneumatic Connections

The pneumatic connections are located on the right-hand side of the positioner.

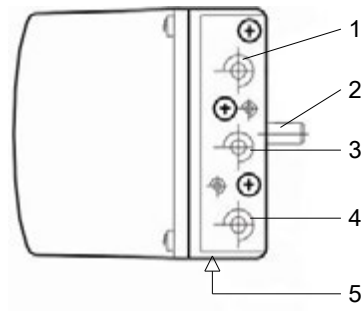

| | |
|---|--|
| 1 | Actuating pressure Y1 in single-acting and double-acting actuators |
| 2 | Feedback shaft |
| 3 | Air supply P_z |
| 4 | Actuating pressure Y2 on double-acting actuators |
| 5 | Exhaust air outlet E with silencer on the underside of the device |

Illustration 5: Pneumatic connections

Connection variants

The following pneumatic connections are located at the rear of the positioner for the integrated fitting of single-acting linear actuators:

- actuating pressure Y1
- exhaust air outlet E

With the exception of the integrated ARCA fitting, these connections are sealed by screws.

The exhaust air outlet can be used for the blanketing of the sensing area and the spring chamber with dry, instrumentation-quality air to prevent corrosion.

Figure 6 illustrates the versions of the pneumatic connections for the various types of actuator, the positioning effect and the safety position after failure of the auxiliary power supply.



CAUTION

Note before working on the control valve

You must place the control valve in the safe position before working on it. Make sure that the control valve has reached the safe position. If you only interrupt the pneumatic auxiliary power to the positioner, it may take a certain time for the safe position to be reached.

| Actuating pressure Connection | Actuator type | Safety position after auxiliary power failure | | |
|-------------------------------|---------------|---|--|---|
| | | Electric | Pneumatic | |
| Y1 | | Closed | Closed | <p>With part-turn actuators the counterclockwise direction of rotation - viewed on the actuating shaft of the valve - is defined as "Open".</p> |
| Y1 | | Open | Open | |
| Y2 | Y1 | Open | Last position (before auxiliary power failure) | |
| Y1 | Y2 | Closed | | |
| Y1 | | Closed | Closed | |
| Y1 | | Open | Open | |
| Y2 | Y1 | Open | Last position (before auxiliary power failure) | |
| Y1 | Y2 | Closed | | |

Illustration 6: Pneumatic connection positioning effect

6.3.4 Purging Air Switch

The purging air switch is accessible above the pneumatic connection strip on the valve block when the housing is open.

- In the IN position the interior of the housing is flushed by very small quantities of clean, dry instrumentation-quality air.

- In the OUT position, the purging air is fed directly outside.

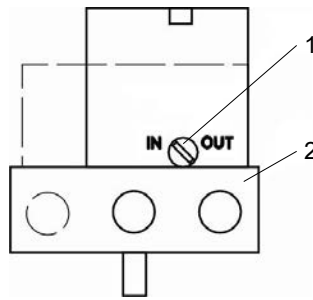

- | | |
|---|----------------------------|
| 1 | Purging air switch |
| 2 | Pneumatic connection strip |

Illustration 7: Purging air switch on the valve block

6.3.5 Restrictors

The exhaust valve is always open in the de-energised state.

- In order to achieve actuating times of > 1.5 s with small actuators, it is possible to reduce the air flowrate by means of the restrictors Y1 and Y2.
- By turning to the right, the air power is reduced until it is completely blocked.
- In order to adjust the restrictors, it is recommended that they are closed and then slowly opened (see initialisation RUN3).
- Take care in the case of double-acting actuators that both restrictors are set approximately equal.

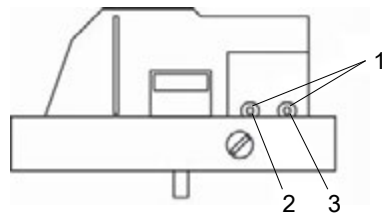

- | | |
|---|-------------------|
| 1 | 2.5 mm hex socket |
| 2 | Y1 |
| 3 | Y2 |

Illustration 8: Restrictors

7 Assembly

7.1 Safety instructions for assembly

CAUTION

Improper assembly

Improper assembly can result in damage to the device, its destruction or the impairment of its function.

Ascertain that the device shows no visible signs of damage each time before installing it.

Ascertain that the process connections are clean and that suitable seals and cable glands are used.

Assemble the device using suitable tools.



⚠ CAUTION

Effect of mechanical impact

It is essential that the following sequence is observed during assembly in order to avoid injury or mechanical damage to the positioner/mounting kit:

- ▶ Mechanically mount the positioner
- ▶ Connect the auxiliary electrical power supply
- ▶ Connect the pneumatic auxiliary power
- ▶ Carry out the commissioning procedure

ATTENTION

Loss of the device protection class

Damage to the device due to open or improperly closed housing. The protection class specified on the type plate is no longer guaranteed.



⚠ CAUTION

Humid environment/dry compressed air

If the environment is humid, mount the positioner in such a way that there is no chance of the control axis freezing solid at low ambient temperatures.

Make sure that water does not enter an open housing or threaded joint. If the positioner cannot be immediately and permanently mounted and connected on site, it is possible for water to enter.

In general, only dry compressed air may be used to operate the positioner. You should therefore make use of the usual water trap. In extreme cases it may be necessary to use an additional dryer. The use of dryers is particularly important if you operate the positioner at low ambient temperatures. When mounting on the valve block, set the purging air switch above the pneumatic connections to the "OUT" position.

7.2 Mounting a linear actuator

7.2.1 Mounting with mounting kit for "Integrated Fitting Linear Actuator"

Included with the "integrated fitting linear actuator" are (see figures below for serial numbers):

| Serial no. | No. of items | Name | Note |
|------------|--------------|-----------------------------|------------------------|
| 1 | 1 | Driver pin cpl. with roller | mounted on lever (2) |
| 2 | 1 | Lever | |
| 3 | 2 | Washer | B6.4 - DIN 125 - A2 |
| 4 | 1 | Spring washer | A6 – DIN 137A- A2 |
| 5 | 1 | Lock washer | A6 – DIN 127- A2 |
| 6 | 1 | Cylinder head bolt | M6 x 25 DIN 7984 - A2 |
| 7 | 1 | Hexagonal nut | M6 - DIN 934 - A4 |
| 8 | 1 | Square nut | M6 - DIN 557 - A4 |
| 9 | 2 | Cylinder head bolt | M8 x 65 - DIN 912 - A2 |
| 10 | 2 | Lock washer | A8 - DIN 127 - A2 |
| 11 | 2 | Screw plug | |
| 12 | 1 | O-ring | 13 x 2.5 |

Assembly procedure (see illustrations below)

1. Fig. 9: Adjust the pin (1) on the previously assembled lever to the value of the stroke range given on the actuator or, if this is not available as a scale value, to the next larger scale value. In case of uncertainty with regard to the actual working stroke (pneumatic actuators often have a setting distance reserve), the next larger scale value should be selected. The centre of the pin should rest on the scale line on the lever. The same value can be set later during the commissioning under the parameter "3.YWAY", in order to display the setting distance in mm after the initialisation.
2. Fig. 10: Push the lever to the stop on the controller axis, and fix it with cylinder head screw (6).
3. Open the rear actuating pressure outlet by removing the screw (13) and the O-ring (14).
4. When fitting with spring chamber exhaust air supply open the exhaust air outlet by removing the screw (15) and the O-ring (16).
5. Fig. 11: Seal the actuating pressure outlet with screw plug (11). When fitting with exhaust air blanketing remove exhaust air silencer and seal.
6. Insert the O-ring (12) in the yoke recess.
7. Locate the positioner on the actuator in such a way that the roller passes between the pins (17).
8. Align the controller horizontally at the yoke, and assemble it with the screws (9) and lock washers (10).

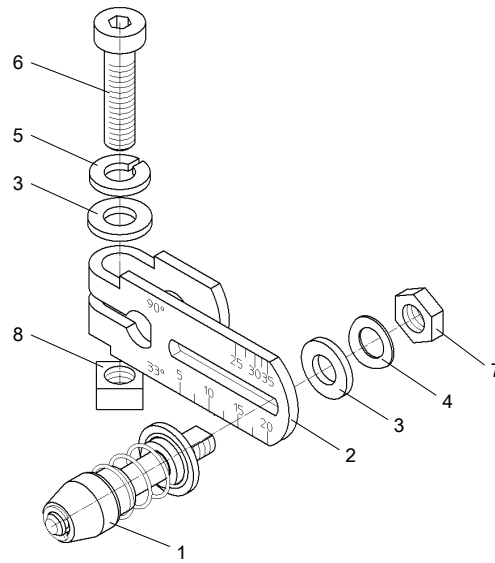
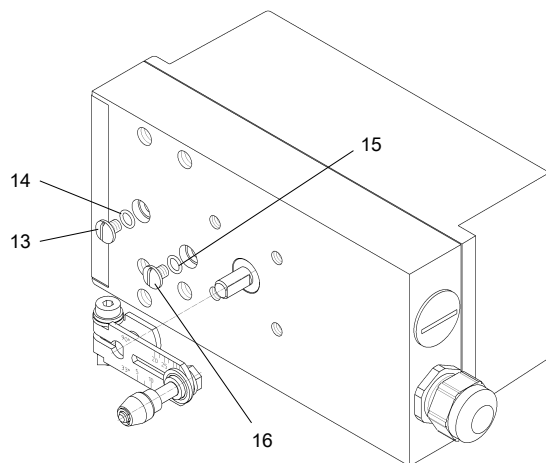
**Assembly procedure plan -
integrated fitting***Illustration 9: Lever mounted**Illustration 10: Mounting the lever on the positioner*

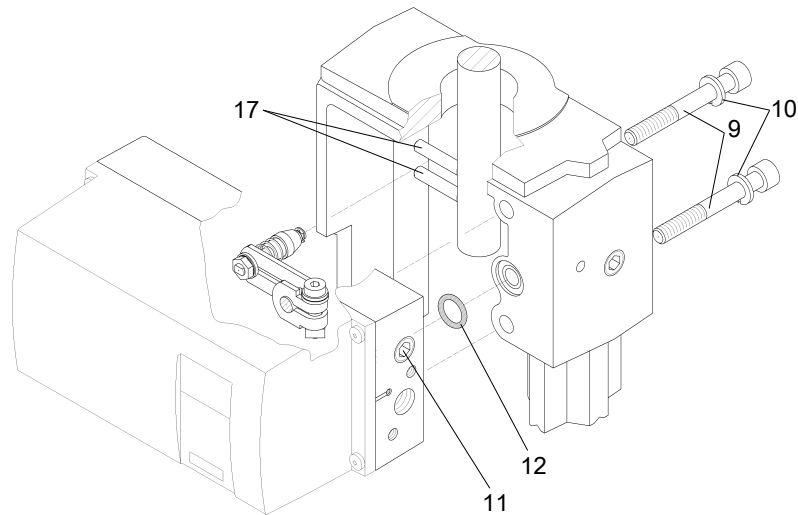

Illustration 11: Mounting the positioner on the actuator

7.2.2 Mounting with mounting kit "Linear actuator IEC 534"

Included with the mounting kit "Linear actuator IEC 534", stroke 3 to 35 mm, are (see figures below for serial numbers):

| Serial no. | No. of items | Name | Note |
|------------|--------------|-----------------------------|---|
| 1 | 1 | NAMUR fitting angle IEC 534 | Standardised connecting location for fitting bracket with rib, column or flat surface |
| 2 | 1 | Sensing hoop | Guides the roller with the driver pin and turns the lever arm |
| 3 | 2 | Clamping piece | Assembly of the sensing hoop to the actuator's spindle |
| 4 | 1 | Driver pin cpl. with roller | mounted on lever (5) |
| 5 | 1 | NAMUR lever | For stroke range 3 mm to 35 mm, or (order separately for stroke range > 35 mm to 130 mm, see Fig. 10) |
| 6 | 2 | U-bolts | Only for actuators with columns |
| 7 | 4 | Hexagonal screw | M8 x 20 DIN 933-A2 |
| 8 | 2 | Hexagonal screw | M8 x 16 DIN 933-A2 |
| 9 | 6 | Lock washer | A8 - DIN 127-A2 |
| 10 | 6 | Washer | B 8.4 - DIN 125-A2 |
| 11 | 2 | Washer | B 6.4 - DIN 125-A2 |
| 12 | 1 | Spring washer | A6 - DIN 137A-A2 |
| 13 | 3 | Lock washer | A6 - DIN 127-A2 |
| 14 | 3 | Cylinder head bolt | M6 x 25 DIN 7984-A2 |
| 15 | 1 | Hexagonal nut | M6 - DIN 934-A4 |
| 16 | 1 | Square nut | M6 - DIN 557-A4 |
| 17 | 4 | Hexagonal nut | M8 - DIN 934-A4 |

Assembly procedure (see illustrations below)

1. Fig. 13: Assemble the clamping pieces (3) using the hexagonal screws (14) and lock washers (13) to the actuator spindle.
2. Push the sensing hoop (2) into the cut-outs in the clamping piece. Adjust to the required length, and tightened the screws so that it is still just possible to push the sensing handle.
3. Fig. 14: Adjust the pin (4) on the previously assembled lever to the value of the stroke range given on the actuator or, if this is not available as a scale value, to the next larger scale value. In case of uncertainty with regard to the actual working stroke (pneumatic actuators often have a setting distance reserve), the next larger scale value should be selected. The centre of the pin should rest on the scale line on the lever. The same value can be set later during the commissioning under the parameter "3.YWAY", in order to display the setting distance in mm after the initialisation.
4. Push the lever to the stop on the controller axis, and fix it with cylinder head screw (14).
5. Fig. 15: Mount the mounting bracket (1) to the rear of the positioner with two hexagonal screws (8), lock washer (9) and washers (10). The choice of the row of holes depends on the width of the actuator's lantern width. The roller should engage in the sensing hoop (2) as close to the spindle as possible, but must not touch the clamping piece.
6. Fig. 16: Hold the positioner with the fixing angle to the actuator in such a way that the pin (4) passes inside the sensing hoop (2).
7. Tighten the sensing hoop.
8. Prepare the assembly parts in accordance with the actuator type:
 - Actuator with a rib: hexagonal bolt (7), lock washer (10) and washer (11).
 - Fig. 17: Actuator with a flat surface: four hexagonal bolts (7) with washer (10) and lock washer (9).
 - Fig. 18: Actuator with columns: two U-bolts (6), four hexagonal nuts (17) with washer (10) and lock washer (9).
9. Attach the positioner with the previously prepared assembly parts to the yoke. Adjust the height of the positioner so that the horizontal position of the lever is achieved as close as possible to the centre of the stroke. The actuator's lever scale provides orientation here. It is essential that the horizontal lever position is passed through within the range of the stroke.

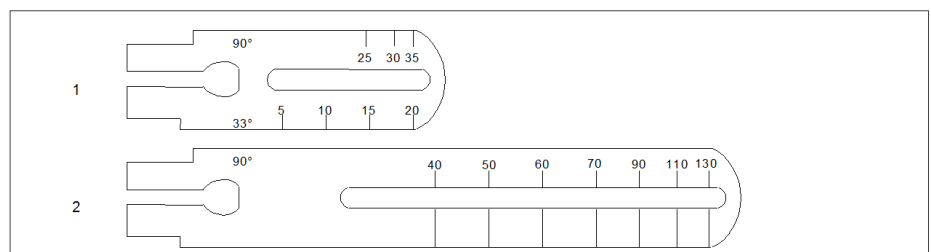

Illustration 12: NAMUR lever 3 mm to 35 mm (1), NAMUR lever > 35 mm to 130 mm (2)

Assembly procedure - linear actuator IEC

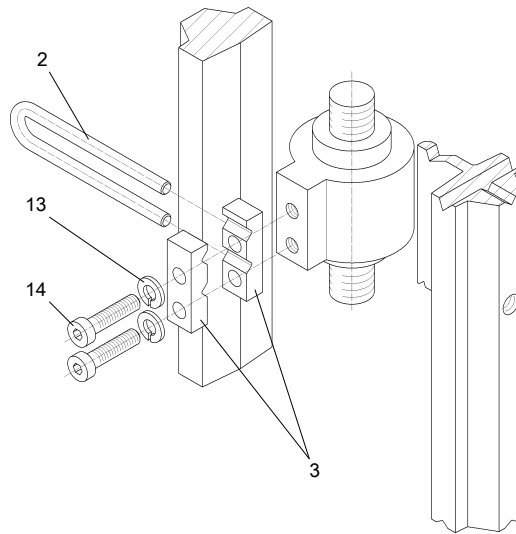

Illustration 13: Mounting the stroke tap on the drive spindle

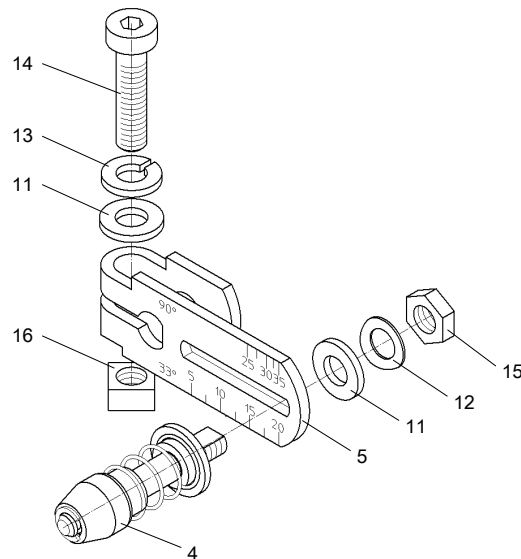

Illustration 14: Lever mounted

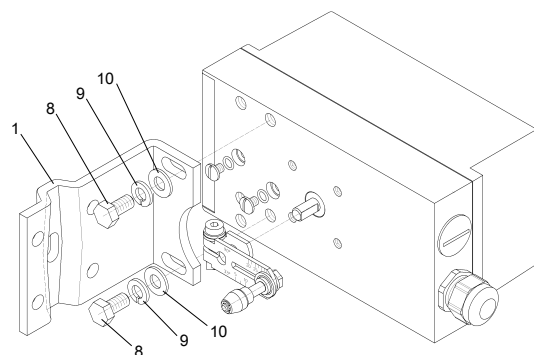

Illustration 15: Mounting the NAMUR mounting bracket

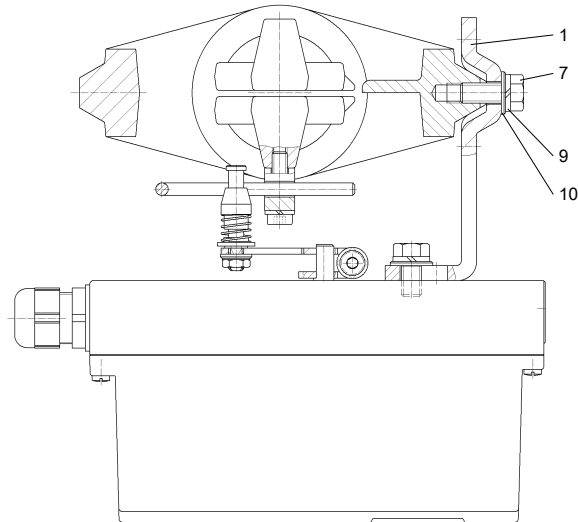

Illustration 16: Mounting the positioner on an actuator with a rib

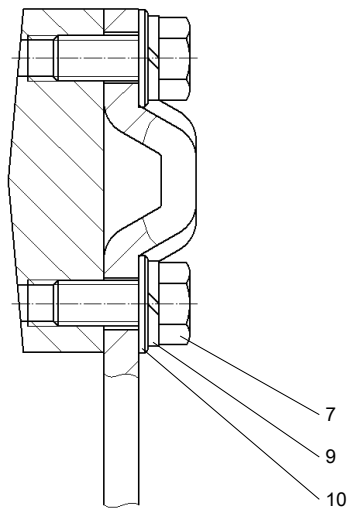

Illustration 17: Mounting the positioner on an actuator with a level surface

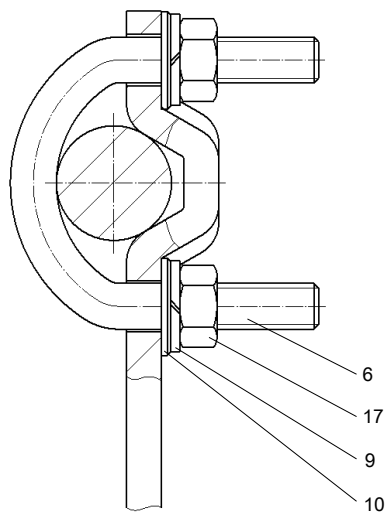

Illustration 18: Mounting the positioner on an actuator with columns

7.3 Mounting with mounting kit "Rotary actuator VDI/VDE 3845"

Included with the mounting kit "Rotary actuator VDI/VDE 3845", are (see figures below for serial numbers):

| Serial no. | No. of items | Name | Note |
|------------|--------------|-----------------------|--|
| 2 | 1 | Coupling wheel | Mounting on the axle of the positioner |
| 3 | 1 | Driver pin | Fitted to the actuator's shaft stub |
| 4 | 1 | Labels | Display of the actuator position, consisting of: 4.1 and 4.2 |
| 4.1 | 8 | Scale | Various divisions |
| 4.2 | 1 | Pointer | Reference point for scale |
| 14 | 4 | Hexagonal screw | DIN 933 - M6 x 12 |
| 15 | 4 | Retaining washer | S6 |
| 16 | 1 | Cylinder head bolt | DIN 84 - M6 x 12 |
| 17 | 1 | Washer | DIN 125 - 6.4 |
| 18 | 1 | Hexagonal socket bolt | Pre-assembled with coupling wheel |
| 19 | 1 | Hexagon key | For item 18 |

Assembly procedure (see illustrations below)

1. Fig. 19: Attach the VDI/VDE 3845 mounting bracket ((9), actuator-specific, supplied by actuator manufacturer) to the rear of the positioner, and fix it in place with the hexagonal screws (14) and retaining washers (15).
2. Stick the pointer (4.2) on the fitting bracket at the middle of the centring hole.
3. Fig. 20: Push the coupling wheel (2) as far as it will go on the positioner axis, pull it back about 1 mm, and tighten the hexagonal socket bolt (18) with the supplied hexagonal key.
4. Fig. 21: Place the driver pin (3) on the actuator's shaft stub and tighten it with cylinder head bolt (16) and washer (17).
5. Fig. 22: Carefully place the positioner with the mounting bracket on the actuator. One of the two pins of the coupling wheel (2) must engage in the driver pin (3). You do not need to adjust the slip clutch if you use the pins (12) as described below. Commissioning is simplified as a result. There is a notch in each of the two pins (20) - see the following diagrams. Use the pin in which the notch has a V-shape (B) for actuators that close in a clockwise direction. Use the pin in which the notch has a rectangular shape (B) for actuators that open in a clockwise direction.
6. Align the positioner / fitting bracket centrally on the actuator, and screw tight (screws are not included with the supply, but are part of the actuator's fitting bracket!).
7. Fig. 23: When commissioning has been completed, take the actuator to its end position and stick the scale (4.1) on to the coupling wheel (2) according to the direction of rotation and the turning range. The scale is self-adhesive.

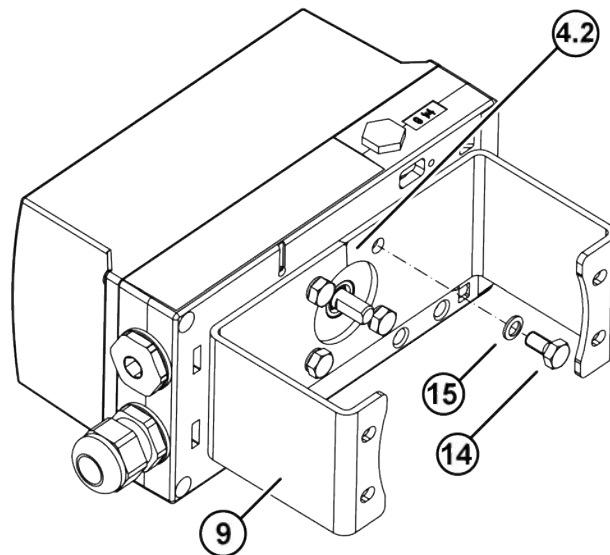
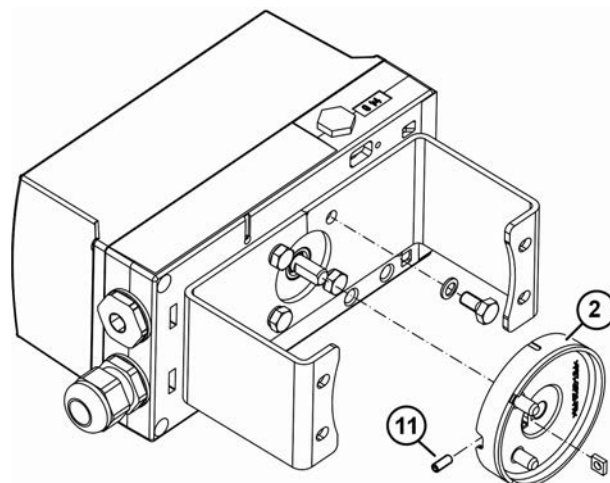
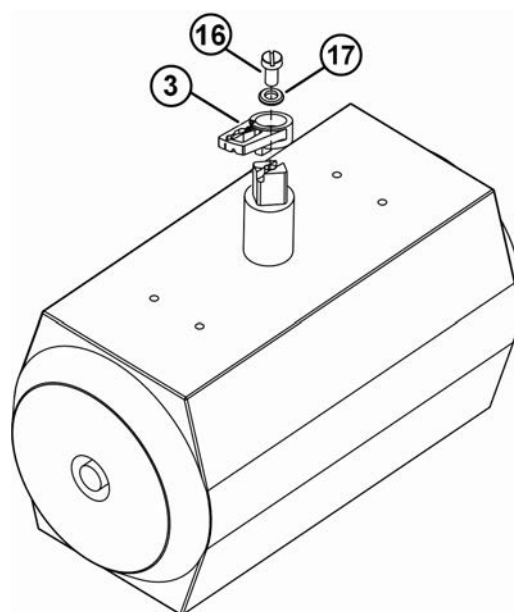
**Assembly procedure for VDI/
VDE 3845 rotary actuator***Illustration 19: Mounting the positioner on the bracket**Illustration 20: Mounting the coupling wheel on the positioner**Illustration 21: Mounting the driver pin on the actuator*

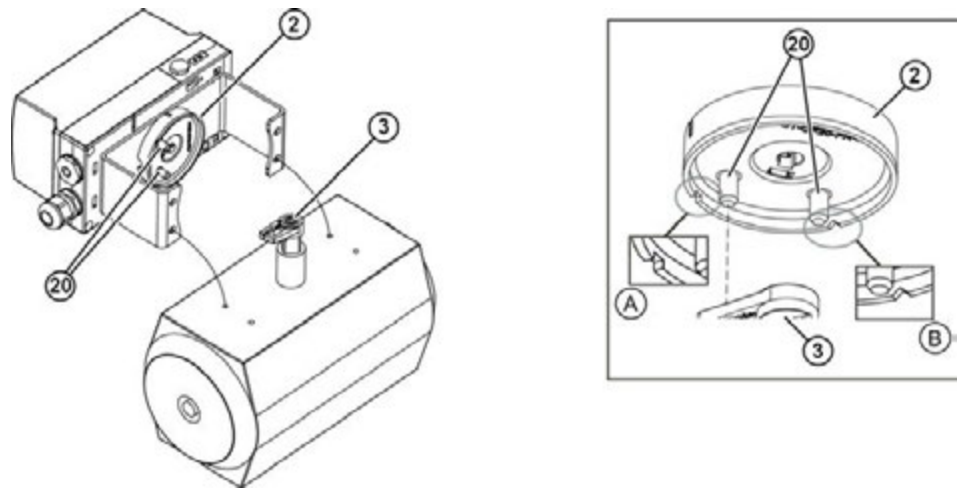

Illustration 22: Mounting the positioner on the actuator

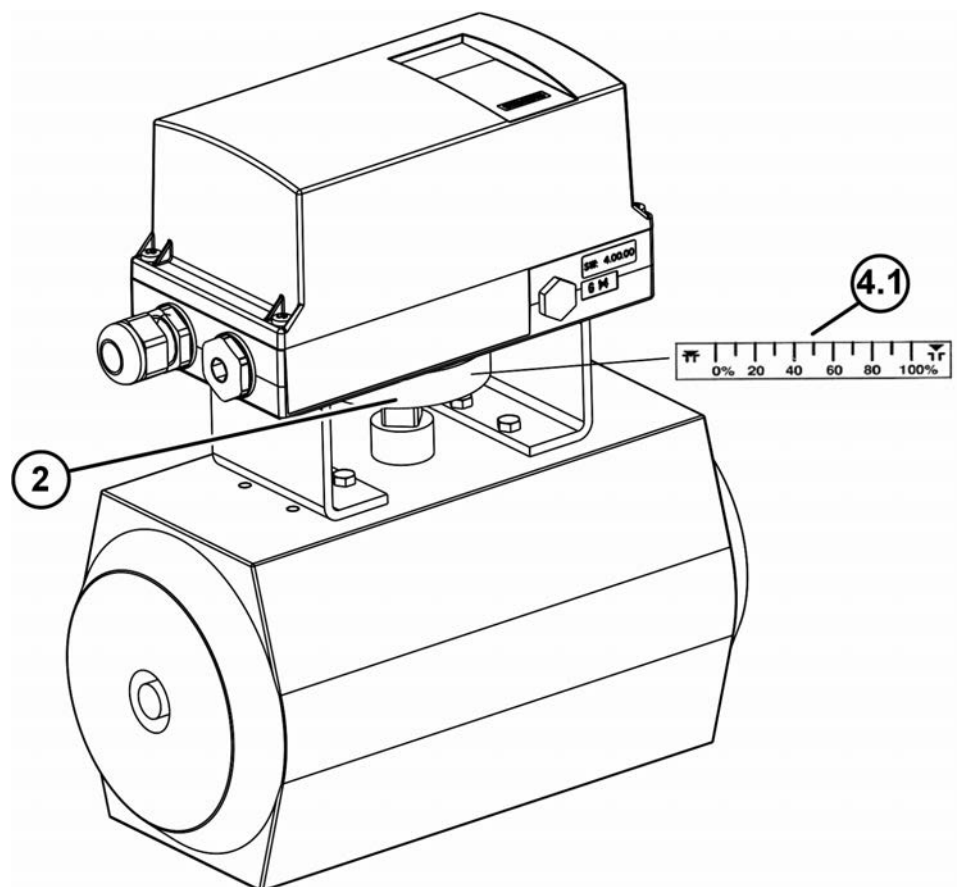

Illustration 23: Mounting the scale

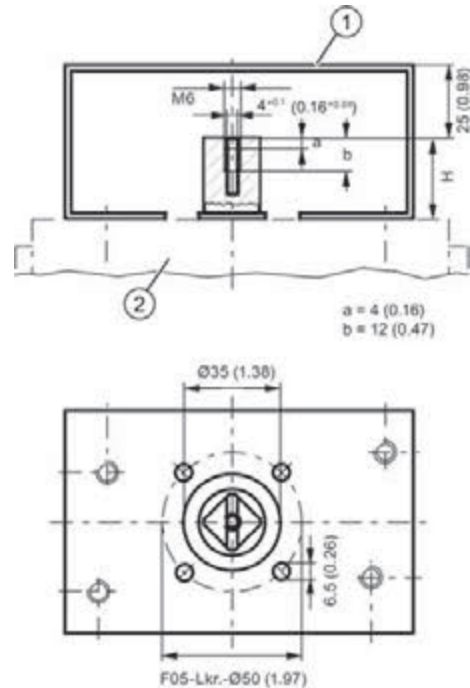

Illustration 24: Mounting bracket (supplied by the actuator manufacturer) and dimensions

7.4 Use of positioners in humid environment

CAUTION

Never clean the positioner with a high pressure cleaner. Protection class IP 66 is inadequate for this.

This information provides you with important notes on mounting and operating the positioner in wet environments (frequent heavy rain and/or persistent tropical condensation) in which protection class IP66 is no longer sufficient, in particular when there is a risk that the water might freeze.

Avoid unfavourable installation positions:

- in order to prevent the penetration of liquids into the device, e.g. through the exhaust air openings, during normal operation.
- As the digital display is otherwise difficult to read.

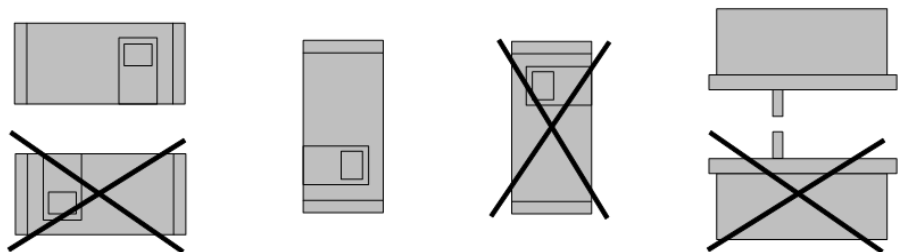

Illustration 25: Favourable and unfavourable installation positions

If local conditions force you to operate the positioner in an unfavourable installation position, you can prevent the entry of water through additional measures.

| | |
|--|---|
| Additional measures | <p>The additional steps necessary to prevent the entry of water depends on the installation position chosen. In certain cases you may need:</p> <ul style="list-style-type: none"> ▪ Threaded joint with sealing rings (e.g. FESTO: CK -1/4 -PK-6) ▪ Plastic hose, approx. 20 to 30 cm (e.g. FESTO: PUN- 8X1.25 SW) ▪ Cable ties (number and length depend on the local conditions) |
| Procedure | <ol style="list-style-type: none"> 1. Assemble the piping in such a way that rainwater or condensation that runs along the length of the pipes can drip off before reaching the positioner's connection strip. 2. Check that the seals for the electrical connections are correctly seated. 3. Check that the seal of the housing cover is not damaged or soiled. Clean or replace it if necessary. 4. If possible, mount the positioner in such a way that the sintered bronze silencer on the underneath of the housing is pointing downwards (vertical installation position). If this is not possible, the silencer should be replaced by a plastic hose using a suitable threaded joint. |
| Assembling the threaded joint with plastic hose | <ol style="list-style-type: none"> 1. Unscrew the sintered bronze silencer from the exhaust air opening on the underside of the housing. 2. Screw the threaded joint mentioned above into the outlet opening. 3. Fit the plastic hose mentioned above to the threaded joint and check that it is tightly seated. 4. Use a cable tie to fasten the plastic hose to the fittings in such a way that the opening is pointing downwards. 5. Check that the hose is not kinked, and that the exhaust air can flow out easily. |

7.5 Positioners that are exposed to high acceleration forces or strong vibrations

High acceleration forces occur on fittings that are heavily mechanically stressed, such as breakaway flaps, heavily shaking or vibrating valves or "steam hammer". These forces can be well outside the range specified in the technical data. In extreme cases this can result in displacement of the slip clutch.

In these cases the positioner is fitted as standard with a locking device for the slip clutch and transmission ratio selector, with which displacement as a result of the above-mentioned influences is inhibited.

The locking device for the slip clutch is accessible underneath the black adjusting wheel and is recognisable by the yellow wheel with slots. The zero point setting and adjustment functions of the slip clutch are marked with symbols on an auxiliary plate.

The locking device for the transmission ratio selector is located underneath the terminals and is similarly fitted with a yellow adjusting wheel with slots.

7.5.1 Slip clutch

Procedure

After the positioner has been fitted and fully set into operation, the slip clutch can be locked as follows:

1. Insert a conventional flat-blade screwdriver about 4 mm wide into a slot in the yellow wheel.
2. Turn the yellow wheel anti-clockwise with the screwdriver until it latches detectably. The slip clutch is thereby locked.
3. A locked slip clutch is to be recognised by an approximately 1 mm wide gap between the yellow and black wheel.
4. If a null point setting is necessary, e.g. after a drive change, the locking is released by a clockwise rotation up to the stop of the yellow wheel. After the null point setting the slip clutch can be fixed again as described above.

7.5.2 Transmission ratio selector

Starting from the neutral position (delivery condition), the transmission ratio selector can be locked as follows:

1. Insert a conventional flat-blade screwdriver about 4 mm wide into a slot in the yellow wheel.
2. Turn the adjusting wheel counter-clockwise or clockwise according to the selected transmission ratio (33° or 90°) until you feel it engage.
3. A locked transmission ratio selector is recognisable by the asymmetrically positioned adjusting wheel.
4. If it should be necessary to switch the transmission ratio, the lock must first be released by turning the adjusting wheel to the neutral position.

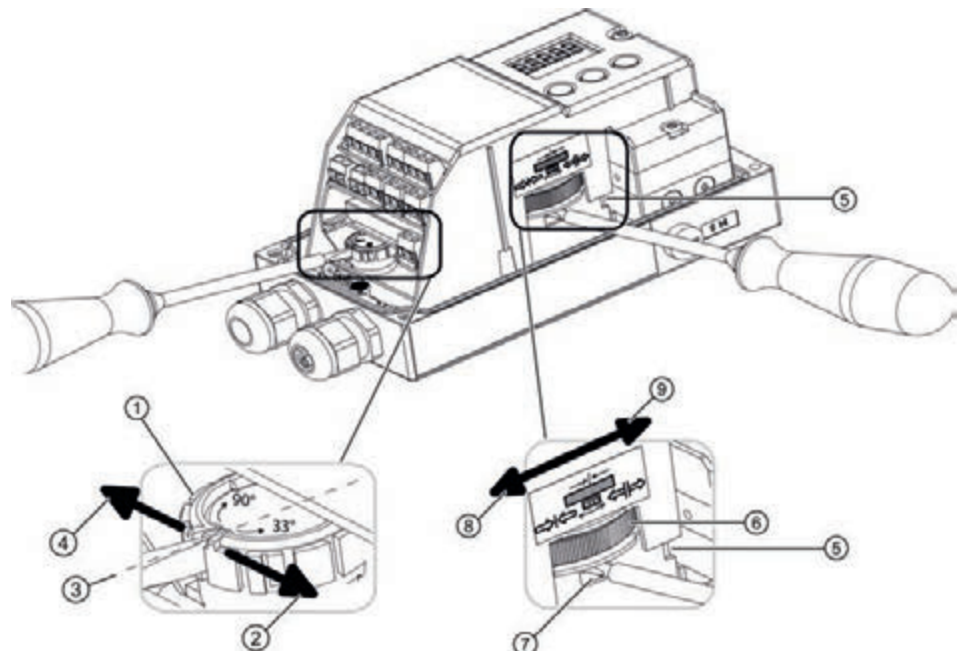

Illustration 26: Locking the slip clutch and the transmission ratio selector / locking device

| | | | |
|---|-----------------------------|---|-----------------------------|
| 1 | Adjusting wheel | 2 | 33° fixed |
| 3 | Neutral position | 4 | 90° fixed |
| 5 | Transmission ratio selector | 6 | Slip clutch adjusting wheel |
| 7 | Slip clutch locking wheel | 8 | locked |

9 loose

External Travel Acquisition

External travel acquisition is a possibility for those cases in which the measures described above are not sufficient, such as when vibration is heavy and persistent, at particularly high or low ambient temperatures, or in the presence of nuclear radiation. In this case the special positioner (see Type Key) is used at a distance from the fitting.

8 Electrical connection

Basic safety instructions



⚠ WARNING

Incorrect power supply

Danger of explosion in potentially explosive areas if the power supply is incorrect, e.g. if alternating current is used instead of direct current.

- ▶ Connect the device in accordance with the prescribed supply and signal circuits. The applicable regulations can be found in the certificates or on the type plate.



⚠ WARNING

Unsafe low-voltage power supply

Danger of explosion in potentially explosive areas due to voltage flashover.

- ▶ Connect the device to a low-voltage power supply with safe isolation.



⚠ WARNING

Connection of the device when live

Risk of explosion in potentially explosive areas

- ▶ Connect the device in potentially explosive areas only when switched off.
 - ⇒ **Exceptions:** energy-restricted circuits may be connected in potentially explosive areas even when live.



⚠ WARNING

Missing potential equalisation

If there is no potential equalisation, there is a danger of explosion in potentially explosive areas due to equalising current or ignition functions.

- ▶ Make sure that potential equalisation is available for the device.
 - ⇒ **Exceptions:** in the case of devices with the ignition protection class Intrinsic Safety "Ex i" it may be possible to dispense with potential equalisation.



⚠ WARNING

Unprotected wire ends

Danger of explosion in potentially explosive areas due to unprotected wire ends.

- ▶ Protect unused wire ends according to IEC/EN 60079-14.



⚠ WARNING

Improper routing of shielded cables

Danger of explosion due to equalisation currents between the potentially explosive area and areas that are not potentially explosive.

- ▶ Earth shielded cables leading into the potentially explosive area at one end only.
- ▶ In case of earthing at both ends, lay a potential equalisation conductor.



⚠ WARNING

Unsuitable cables and/or cable glands

Danger of explosion in potentially explosive areas and if cables and/or cable glands are connected that do not match each other or do not meet the technical requirements.

- ▶ Use only cables and cable glands that meet the specified requirements.
- ▶ Tighten the cable glands according to the specified torques.
- ▶ When replacing cable glands, use only cable glands of the same type.
- ▶ Check the tightness of the cables after installation.

CAUTION

Formation of condensation in the device

Damage to the device due to the formation of condensation if the temperature difference between transport or storage and the place of installation is more than 20 °C.

- Leave the device to stand for a few hours in the new environment before putting it into operation.

CAUTION

Excessively high ambient temperature

Damage to the cable insulation.

- If the ambient temperature is ≥ 60 °C, use heat-resistant cables designed for an ambient temperature at least 20 °C higher.

CAUTION

Connection of a voltage source to a current input

Damage to the device if a voltage source is connected to the current input I_w (terminals 6 and 7).

- Never connect the current input I_w to a voltage source, otherwise the positioner can be destroyed.
- Always use a current source with a maximum output current I of 20 mA.



⚠ WARNING

"Ex i" version

Only certified, intrinsically safe electrical circuits may be connected as auxiliary power, control or signal circuits.

For reasons of tightness (IP housing protection class) and the necessary tensile strength, use only cables with diameter of ≥ 8 mm (or a suitable sealing insert in the case of smaller cable diameters) with the standard cable gland M20x1.5.

In the NPT version the positioner is supplied with an adaptor. Make sure when inserting a mating part in the adaptor that the maximum permissible torque of 10 Nm is not exceeded.

2-wire operation

To maintain the auxiliary power, the input current I_w must be 3.6 mA.

8.1 Electrical connection of basic device

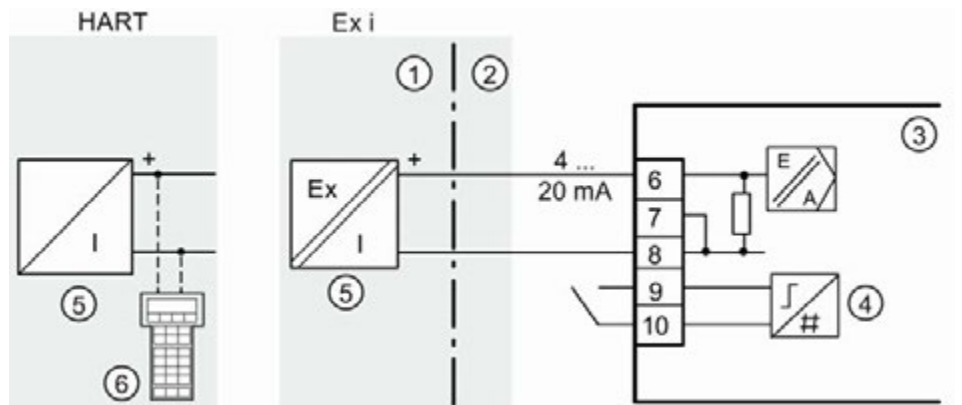

Illustration 27: 2-wire connection of 2-wire device

| | |
|-------------------------------|---------------------|
| 1 Area of no explosive hazard | 4 Binary input 1 |
| 2 Potentially explosive area | 5 Signal source |
| 3 Main electronic board | 6 HART communicator |

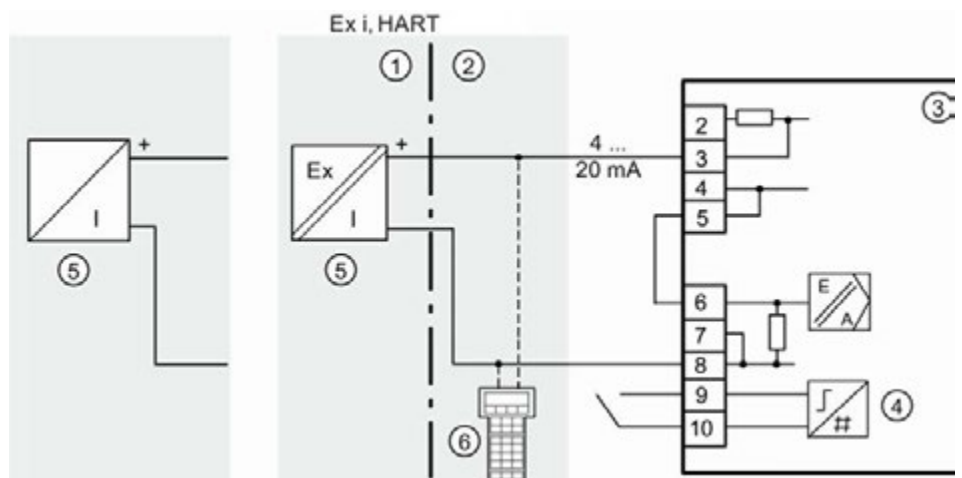

Illustration 28: 2-wire connection of 2/3/4-wire device

| | |
|-------------------------------|---------------------|
| 1 Area of no explosive hazard | 4 Binary input 1 |
| 2 Potentially explosive area | 5 Signal source |
| 3 Main electronic board | 6 HART communicator |

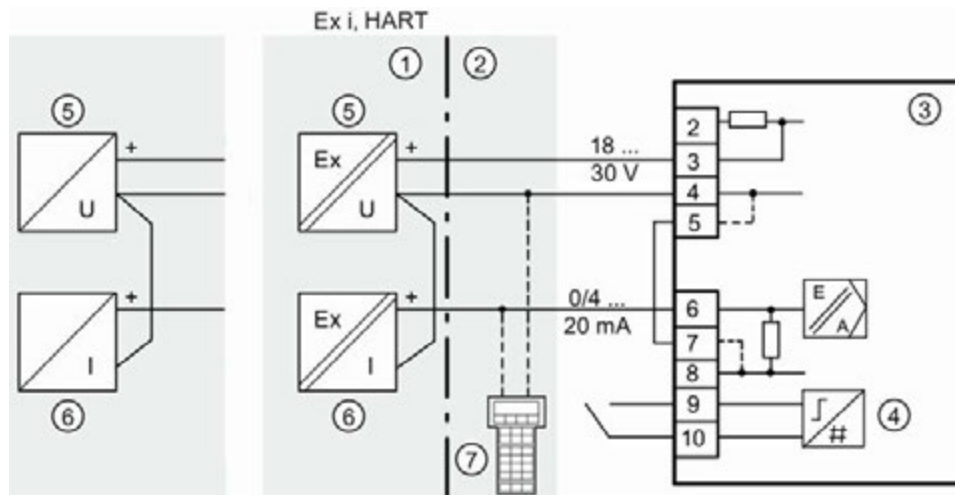

Illustration 29: 3-wire connection of 2/3/4-wire device

| | |
|-------------------------------|---------------------|
| 1 Area of no explosive hazard | 5 Supply source |
| 2 Potentially explosive area | 6 Signal source |
| 3 Main electronic board | 7 HART communicator |
| 4 Binary input 1 | |

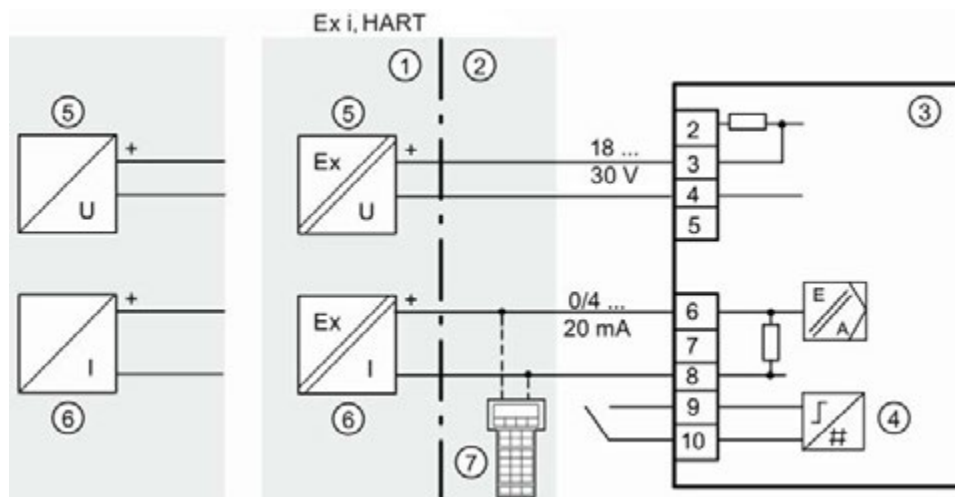

Illustration 30: 4-wire connection of 2/3/4-wire device

| | |
|-------------------------------|---------------------|
| 1 Area of no explosive hazard | 5 Supply source |
| 2 Potentially explosive area | 6 Signal source |
| 3 Main electronic board | 7 HART communicator |
| 4 Binary input 1 | |

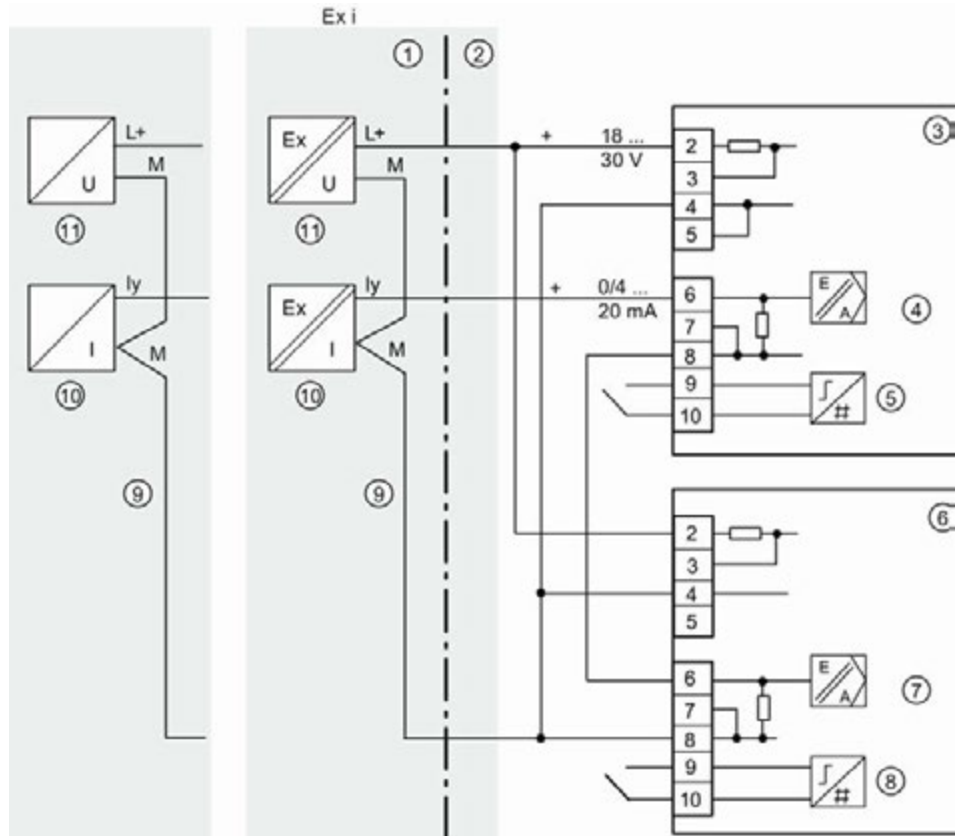

Illustration 31: Series connection of 2 positioners, e.g. split-range operation

| | |
|-------------------------------|---------------------------------|
| 1 Area of no explosive hazard | 6 Device 2 |
| 2 Potentially explosive area | 7 Positioning range 2 |
| 3 Device 1 | 8 Binary input 2 |
| 4 Positioning range 1 | 9 Total positioning range I_y |
| 5 Binary input 1 | 10 Signal source |
| | 11 Supply source |

8.2 Electrical connection options

Analog module

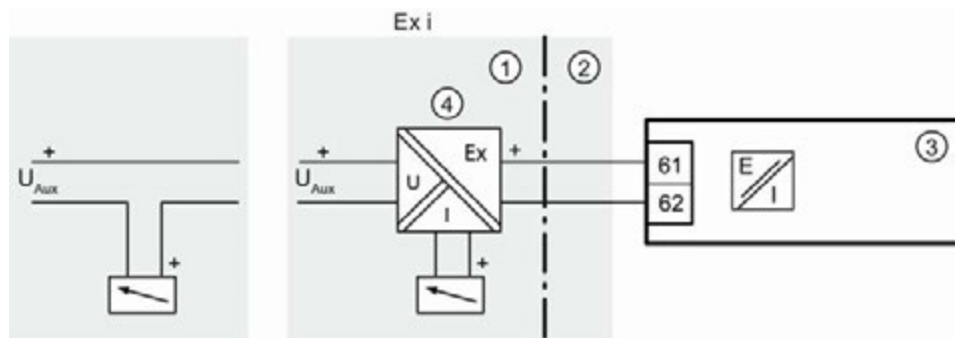

Illustration 32: Analog module

| | |
|-------------------------------|----------------------------|
| 1 Area of no explosive hazard | 3 Position feedback module |
| 2 Potentially explosive area | 4 Supply isolator |

Binary module

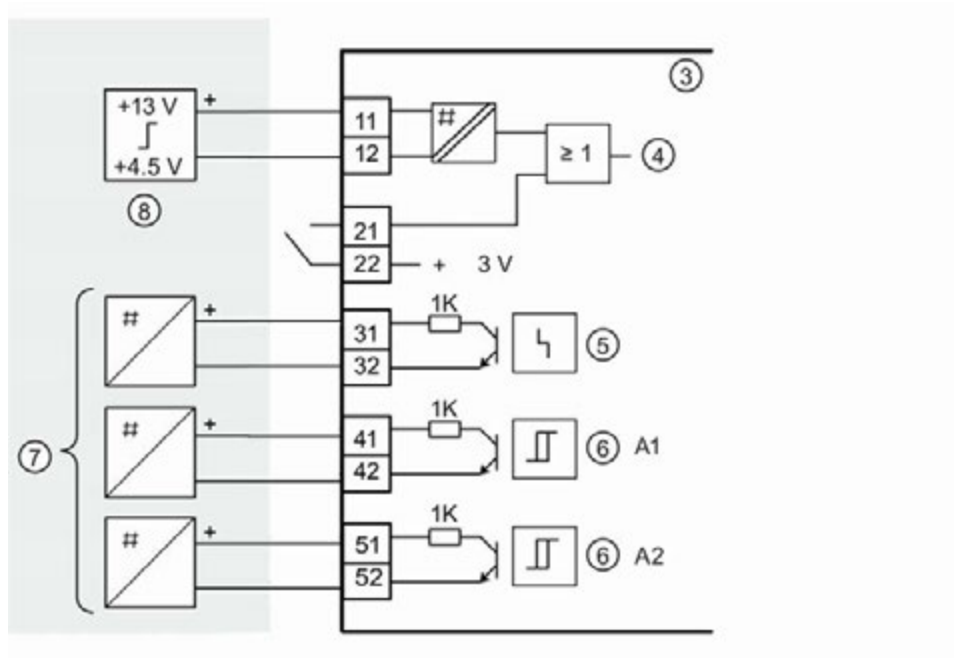

Illustration 33: Binary module without explosion protection

| | |
|-------------------------------|-----------------------|
| 1 Area of no explosive hazard | 5 Fault signal |
| 2 Potentially explosive area | 6 Limit value |
| 3 Alarm module | 7 Switching amplifier |
| 4 Binary input 2 | 8 Switch output |

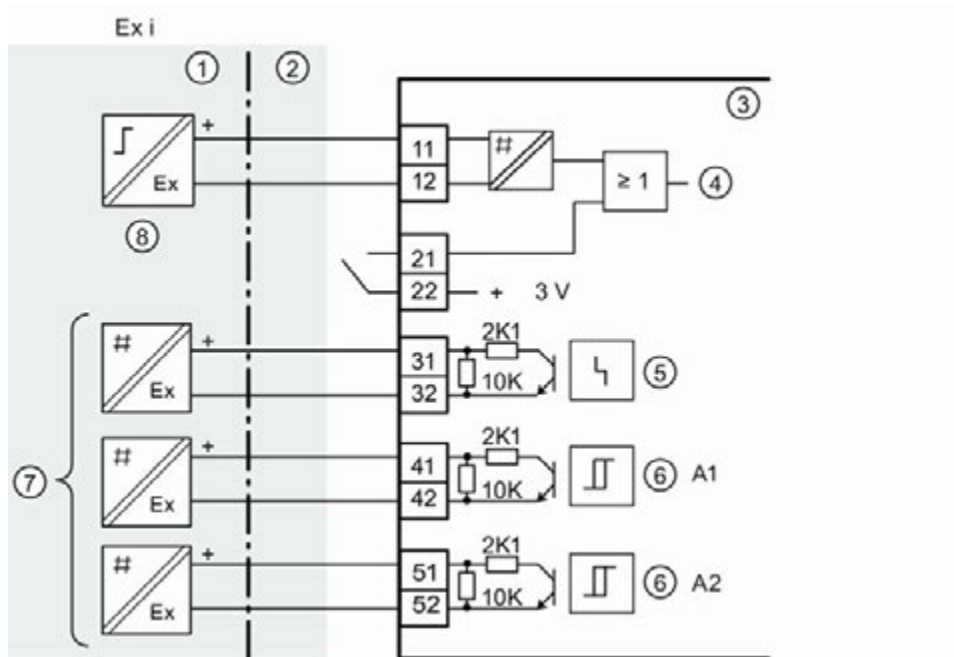

Illustration 34: Binary module in "Ex i" version

| | |
|-------------------------------|-----------------------|
| 1 Area of no explosive hazard | 5 Fault signal |
| 2 Potentially explosive area | 6 Limit value |
| 3 Alarm module | 7 Switching amplifier |
| 4 Binary input 2 | 8 Switch output |

Slot initiator module

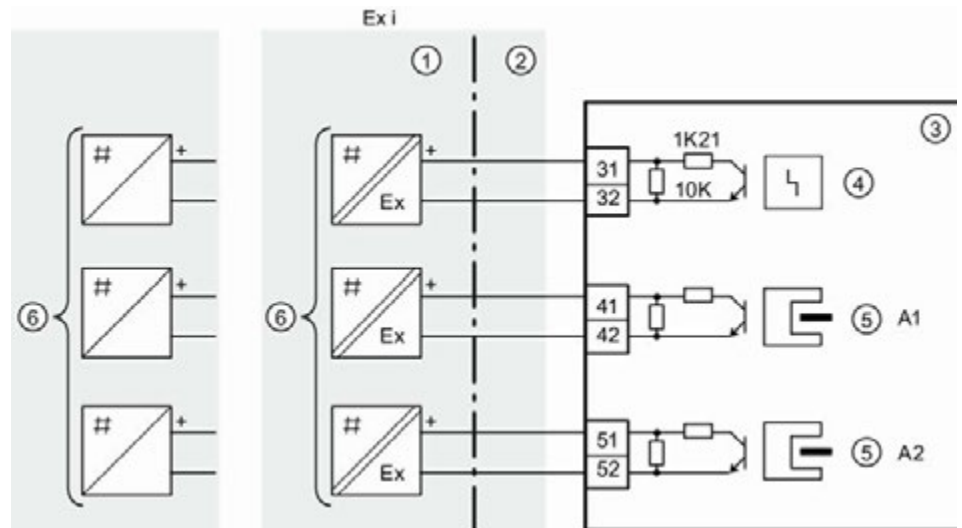

Illustration 35: Slot initiator module

| | |
|-------------------------------|-----------------------|
| 1 Area of no explosive hazard | 4 Fault signal |
| 2 Potentially explosive area | 5 Limit value |
| 3 SIA module | 6 Switching amplifier |

Contact module

**⚠ DANGER****Low-voltage supply / version without explosion protection**

If you supply the device with low voltage in the non-intrinsically-safe device version, you must observe the following safety rules without fail before working on the device:

- ▶ Switch the device off. Use a means of isolation located near the device for this.
- ▶ Secure the device against being switched on again.
- ▶ Check that the device is really free from voltage.

**⚠ WARNING****Protection against mechanical influences**

In order to guarantee protection class IP66, you must protect the module against mechanical influences. This is done by choosing a suitable place of installation or mounting a suitable safeguard. This obligatory protection applies to the operation of the module with the following voltages:

- ▶ > AC 16 V
- ▶ > DC 35 V, low voltage

ATTENTION**Maximum value of terminals 41/42 and 51/52 - version without explosion protection**

The following maximum values refer exclusively to terminals 41 and 42 as well as terminals 51 and 52:

- Maximum voltage: AC 250 V or DC 24 V
- Maximum current: AC/DC 4 A

Safe isolation between the terminals is not guaranteed.

ATTENTION

Maximum value of terminals 41/42 and 51/52 - "Ex i" version

The following maximum values refer exclusively to terminals 41 and 42 as well as terminals 51 and 52:

- Maximum voltage: DC 30 V
- Maximum current: DC 100 mA
- Maximum power: 750 mW

Safe isolation between the terminals is not guaranteed.

ATTENTION

To be observed before installation and connection

- Exclusively qualified personnel are authorised to install and connect the contact module.
- Disconnect all cables from sources of electricity and check that they are really free from voltage.
- Dimension the cross-sectional area of the connecting cables such that it corresponds to the permissible current load.
- Select the cables according to the following rules: The permissible operating temperature of the cables must be 25 °C higher than the maximum ambient temperature.
- Operate the Ex version only in intrinsically safe electrical circuits with approved switching amplifiers.

ATTENTION

Preparation of the cables or wires - "Ex i" version

- Strip the cable insulation back so that the insulation is flush with the terminal when the wires are inserted.
- In the case of wires, fit the ends with wire-end ferrules.

Connection of the contact module (see fig. 36).

1. Loosen the screw (18) on the transparent cover (19).
2. Pull the transparent cover (19) forwards to the front stop.
3. Screw each cable tight in the respective terminal.
4. Push the transparent cover (19) to the stop on the motherboard.
5. Tighten the screw (18) on the transparent cover (19).

- Fasten the cables for each switch in pairs to the lugs on the PCB. Use the cable ties (20) provided for this.

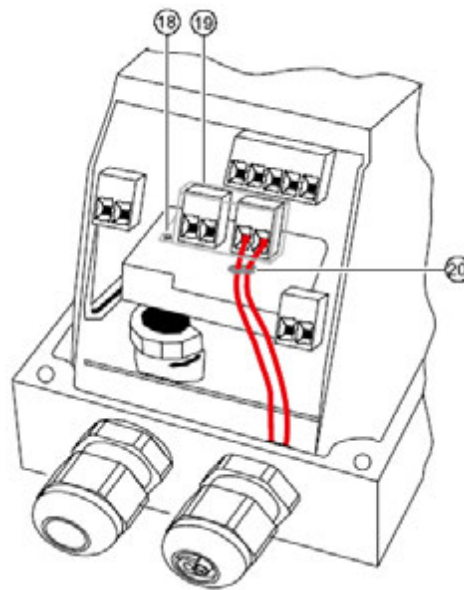

| | |
|----|-----------|
| 18 | Screw |
| 19 | Cover |
| 20 | Cable tie |

Illustration 36: Cable fastening

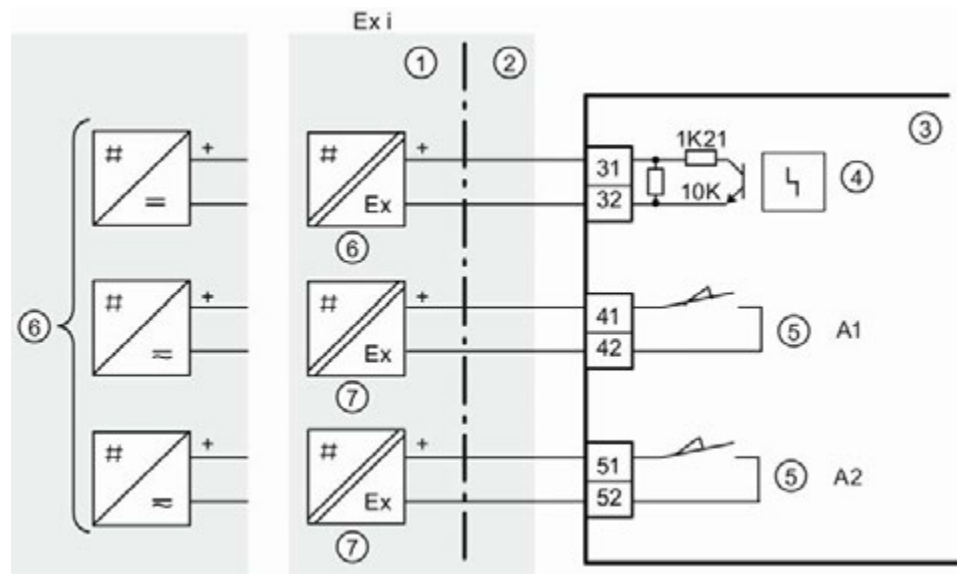

Illustration 37: Contact module

| | | | |
|---|-----------------------------|---|---------------------|
| 1 | Area of no explosive hazard | 5 | Limit value |
| 2 | Potentially explosive area | 6 | Switching amplifier |
| 3 | Limit value contact module | 7 | Switch output |
| 4 | Fault signal | | |

8.3 Optional version M12 plug

This section describes which terminal of the devices and option modules listed below is connected to which pin of the M12 plug.

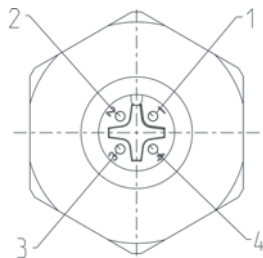

Illustration 38: Pin diagram - seen from pin side

| Pin designation | Wire colour M12 plug |
|-----------------|----------------------|
| 1 | brown |
| 4 | black |
| 3 | blue |
| 2 | white |

M12 plug in 2-wire basic device

| Current input terminal | Pin designation |
|---------------------------|-----------------|
| 6 (+) | 1 - brown |
| Housing shield connection | 4 - black |
| 7 and 8 (-) | 3 - blue |

M12 plug for analogue module

| Current input terminal | Pin designation |
|---------------------------|-----------------|
| 61 (+) | 1 - brown |
| Housing shield connection | 4 - black |
| 62 (-) | 3 - blue |

M12 plug for binary and slot-type proximity switch module

| Alarm output terminals | Pin designation |
|------------------------|-----------------|
| 41 (+) | 1 - brown |
| 42 (-) | 3 - blue |
| 51 (+) | 2 - white |
| 52 (-) | 4 - black |

M12 plug for external displacement sensor

| Terminal | Pin designation |
|-------------|-----------------|
| GND (X1/1) | 4 - black |
| POT (X1/2) | 3 - blue |
| VREF (X1/3) | 2 - white |
| VCC (X1/4) | 1 - brown |

9 Pneumatic connection



WARNING

For reasons of safety, the auxiliary pneumatic energy should only be connected after assembly when, in the presence of an electrical signal, the positioner is switched to the P-manual operating mode. (Delivery status, see leaflet “Concise operating notes”).

ATTENTION

Ensure correct air-quality!

Oil-free, instrument-quality air with no water or dust, solid material content max. 1 mg/m³ (standard atmospheric conditions), max. particle size 1 mm, oil content max. 0.1 mg/m³ (standard atmospheric conditions), pressurised dew point 20 K below the lowest ambient temperature.

When working on the compressed air system ensure that any contamination present such as water, oil, chips, soldering material residues, etc. are expelled by blowing out.

Procedure:

1. If appropriate, connect manometer block for air supply and actuating pressure.
2. Connection via internal thread:
 - P_z: air supply 1.4 to 7 bar
 - Y1: actuating pressure 1 for single-acting and double-acting actuators
 - Y2: actuating pressure 2 for double-acting actuators
 - E: exhaust air output (remove silencer if necessary)
3. Safety position at failure of auxiliary electrical power:
 - Single-acting: Y1 = vented
 - Double-acting: Y1 = max. actuating pressure (supply pressure)
 - Double-acting: Y2 = vented
4. Connect actuating pressure Y1 or Y2 (double-acting actuators only) according to the desired safety position.
5. Connect air supply to P_z.

So that spring-loaded pneumatic actuators can reliably exploit the maximum possible setting distance, it is necessary that the supply pressure exceeds the maximum required final pressure of the actuator by a sufficient margin.

Check the leak-tightness of the entire valve after mounting the pneumatic connections. Apart from constant consumption of air, a leak results in the positioner constantly trying to correct the position deviation. The consequence is premature wear of the entire control device.

10 Commissioning

See leaflet "Concise operating notes"!



⚠ WARNING

Improper commissioning in potentially explosive areas.

Failure of device or danger of explosion in potentially explosive areas

- ▶ Do not put the device into operation until it is completely assembled and connected.
- ▶ Consider the effects on other devices in the plant before commissioning.



⚠ WARNING

Loss of the explosion protection

Danger of explosion in potentially explosive areas due to open or improperly closed device.



⚠ WARNING

Opening the device when live

Risk of explosion in potentially explosive areas

- ▶ Open the device only when it is switched off.
- ▶ Before commissioning, check that the cover, the cover fastenings and the cable glands have been fitted properly.
 - ⇒ **Exceptions:** devices of the ignition protection class Intrinsic Safety "Ex i" may also be opened in a potentially explosive area when switched on.



⚠ WARNING

Water in the compressed air line

Device damage and possible loss of the ignition protection class. The purging air switch is factory-preset to "IN". In the "IN" position, water from the compressed air line can get into the device through the pneumatics during the initial commissioning.

- ▶ Before commissioning, make sure that there is no water in the compressed air line.
 - ⇒ If you cannot be sure that there is no water in the compressed air line:
- ▶ Switch the purging air switch to "OUT". This prevents water from the compressed air line getting into the device.
- ▶ Set the purging air switch back to "IN" only after all the water has been removed from the compressed air line.

ATTENTION

Loss of the device protection class

Damage to the device due to open or improperly closed housing. The protection class specified on the type plate is no longer guaranteed.



- Make sure that the device is securely closed.

⚠ WARNING

Commissioning and operation in case of an error message

If an error message is displayed, the proper operation in the process is no longer guaranteed.

- ▶ Check the severity of the error.
- ▶ Rectify the error.
- ▶ If an error occurs:
 - ⇒ Switch the device off.
 - ⇒ Prevent it from being switched on again.

ATTENTION

- During initialisation the operating pressure must be at least 1 bar greater than the pressure necessary to open or close the valve. However, the operating pressure may not be greater than the maximum permissible operating pressure of the actuator.
- The transmission ratio selector can only be adjusted when the positioner is open. Check, therefore, that this has been adjusted before closing the housing.

Safety instructions for operation with natural gas

An electrical connection of the protection level "ia", category 2G is necessary for operation with natural gas as the drive medium.

General information

Following the mounting of the positioner on a pneumatic actuator, the positioner must be supplied with pneumatic and electrical auxiliary energy.

Before the initialisation the positioner is in the operating mode "P-manual operation". "NOINI" flashes in the lower line of the digital display.

The positioner is matched to the respective actuator through the initialisation procedure and the setting of parameters. If necessary, the matching of the positioner to the actuator can be undone with the "PRST" parameter. Before this procedure the positioner is once again in the operating mode "P-manual operation".

Initialisation modes

- Automatic initialisation
 - The initialisation takes place automatically. In this case, the positioner determines, one after another, the effective working direction, the stroke or rotation angle and the actuator's adjustment times and adjusts the control parameters to match the dynamic behaviour of the actuator.
- Manual initialisation
 - The stroke or rotation angle of the actuator is set manually. The other parameters are automatically determined, just as in the case of automatic initialisation. You need this function in the case of "soft" end stops.
- Copying Initialisation Data (Positioner Exchange)

The initialisation of a positioner can be read out and loaded to another positioner. This allows a faulty device to be exchanged, without having to interrupt a running process in order to carry out initialisation.

You only have to provide a few parameters to the positioner before initialisation. Due to preset values you do not have to adapt any further parameters for the initialisation

The settings made can be protected against inadvertent change with a correspondingly parameterised and activated binary input.

10.1 Preparation for commissioning of linear actuators

- Assemble the positioner with the appropriate mounting kit. The position of the transmission ratio selector in the positioner is particularly important here.

| Stroke | Lever | Position of the transmission ratio selector |
|--------------|-------|---|
| 5 to 20 mm | short | 33° (i.e. down) |
| 25 to 35 mm | short | 90° (i.e. up) |
| 40 to 130 mm | long | 90° (i.e. up) |

- Connect a suitable source of current or voltage.
- Connect the actuator and the positioner to the pneumatic lines, and activate the positioner's auxiliary pneumatic power.
- The positioner is now in the "P-manual" operating mode. The top line of the display now shows the current potentiometer voltage (P) in percent, e.g.: "P37.5", while "NOINI" flashes on the bottom line:



- Check that the mechanism can move freely over the entire active range by moving the actuator with the \triangle and ∇ buttons as far as the end positions. The value P5.0 may not be fallen below and P95.0 may not be exceeded. The difference of the two values must be greater than 25.0. You can move the actuator rapidly by pressing the button for the opposite direction as well while continuing to hold down the first direction button.
- Now move the actuator so that the lever is horizontal. The display should show a value between P48.0 and P52.0. If this is not the case, make appropriate adjustments to the slip clutch. The more accurately you achieve the value "P50.0", the more precisely the linearisation can take place in the positioner.

10.1.1 Automatic initialisation of linear actuators

When you can move the actuator correctly, leave it in a central position and start the automatic initialisation:

- Press the button longer than 5 s. This will bring you to the configuration mode. Display:



2. Switch to the second parameter "YAGL", by pressing the  switch briefly. Display:



or



This value must absolutely correspond to the setting of the transmission ratio selector (33° or 90°).

3. Use the  button to move on to the following display:

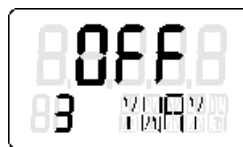

You only have to set this parameter if you want to have the total stroke determined displayed in mm at the end of the initialisation phase. To do this, you select the value in the display at which you have set the driver pin on the scale at the lever.

4. Use the  button to move on to the following display:



5. Start the initialisation by pressing the  button for longer than 5 s. Display:





"RUN1" to "RUN5" appear in sequence in the lower display during the initialisation process. Depending on the actuator, the initialisation can take up to 15 minutes and is completed when the following display appears:



The first line also contains the stroke that has been determined, in mm, if the lever length has been given with the 3.YWAY parameter.

After briefly pressing the  button, the following display appears:



To leave the **Configuration** mode, press the  button for longer than 5 s. The software status will be displayed after about 5 s. When the  button is released, the device will be in manual operation mode.

You can interrupt an initialisation that is in progress at any time by pressing the  button. Your previous settings will be retained. The parameters will only be returned to the factory settings if you have carried out a "Preset".

The slip clutch and the transmission ratio selector can be locked if necessary following successful initialisation.

10.1.2 Manual initialisation of linear actuators

With this function the positioner can be initialised without having to move the actuator hard against the end stops. The start and end positions of the setting distance are set manually.

When you can move the actuator correctly, leave it in a central position and start the manual initialisation. The other initialisation steps (optimisation and control parameters) are carried out in the same way as under automatic initialisation.

1. Press the  button longer than 5 s. This will bring you to the configuration mode. Display:



2. Switch to the second parameter by briefly pressing the  button. Display:



or

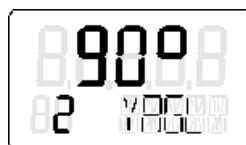

This value must absolutely correspond to the setting of the transmission ratio selector (33° or 90°).

3. Use the  button to move on to the following display:



You only have to set this parameter if you want to have the total stroke determined displayed in mm at the end of the initialisation phase. To do this, you select the value in the display at which you have set the driver pin on the scale at the lever.

4. Press the  button twice to move on to the following display:





5. Start the initialisation by pressing the  button for longer than 5 s.
Display:



6. After 5 s the display changes to:



(The potentiometer settings shown here and below are only illustrative examples.)

Now use the  and  buttons to move the actuator to the position that you wish to define as the first of the two end positions. Then press the  button. This will register the current position as end position 1, and will move on to the next step.

If the message "RANGE" appears on the lower line, the selected end position is outside the permitted measurement range. There are a number of ways to correct this error:

adjust the slip clutch until "OK" appears, then press the operating mode switch again, or

use the  and  buttons to move to a different end position, or



abort the initialisation by pressing the  button. You must then change to P-manual operation and correct the setting distance and the displacement measurement.

7. When Step 6 has been successfully completed, the following display appears:



Now use the \triangle and ∇ buttons to move the actuator to the position that you wish to define as the second end position. Then press the  button. This will cause the current position to be registered as end position 2.

If the message "RANGE" appears on the lower line, the selected end position is outside the permitted measurement range. There are a number of ways to correct this error:

- adjust the slip clutch until "OK" appears, then press the  button again, or
- use the \triangle and ∇ buttons to move to a different end position, or
- abort the initialisation by pressing the  button. You must then change to P-manual operation and correct the setting distance and the displacement measurement.



If the message "Set Middl" appears, the lever arm must be moved to the horizontal position with the aid of the \triangle and ∇ buttons and the  button must then be pressed. This will set the reference point for the sine correction on linear actuators.

8. The rest of the initialisation will now proceed automatically. "RUN1" to "RUN5" will appear in sequence on the lower line of the display. The following display appears when the initialisation has been completed successfully:



The first line also contains the stroke that has been determined, in mm, if the lever length has been given with the 3.YWAY parameter.

After briefly pressing the  button, "5.INITM" will appear again in the lower line. You are then once more in the Configuration operating mode.

To leave the Configuration mode, press the  button for longer than 5 s. The software status will be displayed after about 5 s. When the  button is released, the device will be in manual operation mode.

The slip clutch and the transmission ratio selector can be locked if necessary following successful initialisation.

10.2 Preparation for commissioning of rotary actuators

In the positioner, place the transmission ratio selector in the 90° position (the usual adjustment angle for rotary actuators).

1. Assemble the positioner with the appropriate mounting kit.
2. Connect a suitable source of current or voltage.
3. Connect the actuator and the positioner to the pneumatic lines, and activate the positioner's auxiliary pneumatic power.
4. The positioner is now in the "P-manual" operating mode. The top line of the display now shows the current potentiometer voltage (P) in percent, e.g.: "P37.5", while "NOINI" flashes on the bottom line:



5. Check that the mechanism can move freely over the entire active range by moving the actuator with the \triangle and ∇ buttons as far as the end positions. The value P5.0 may not be fallen below and P95.0 may not be exceeded. The difference of the two values must be greater than 25.0.

You can move the actuator rapidly by pressing the button for the opposite direction as well while continuing to hold down the first direction button.

10.2.1 Automatic initialisation of rotary actuators

When you can move the actuator correctly through its range, leave it in a central position and start the automatic initialisation:

1. Press the \square button longer than 5 s. This will bring you to the configuration mode. Display:



2. Set the parameter to "turn" using the ∇ button. Display:



3. Switch to the second parameter by briefly pressing the \square button. This has automatically been set to 90°. Display:



Note that the transmission ratio selector must be in the 90° position.

4. Use the \square button to move on to the following display:



5. Start the initialisation by pressing the \triangle button for longer than 5 s. Display:





"RUN1" to "RUN5" appear in sequence in the lower display during the initialisation process. Depending on the actuator, the initialisation can take up to 15 minutes and is completed when the following display appears:



The upper value gives the actuator's full turning angle (e.g. 93.5°). After briefly pressing the  button, the following display appears:



To leave the **Configuration** mode, press the  button for longer than 5 s. The software status will be displayed after about 5 s. When the  button is released, the device will be in manual operation mode.

You can interrupt an initialisation that is in progress at any time by pressing the  button. Your previous settings will be retained. The parameters will only be returned to the factory settings if you have carried out a "Preset"

The slip clutch and the transmission ratio selector can be locked if necessary following successful initialisation.

10.2.2 Manual initialisation of rotary actuators

With this function the positioner can be initialised without having to move the actuator hard against the end stops. The start and end positions of the setting distance are set manually.

When you can move the actuator correctly, leave it in a central position and start the manual initialisation. The other initialisation steps (optimisation and control parameters) are carried out in the same way as under automatic initialisation.

1. Press the  button longer than 5 s. This will bring you to the configuration mode. Display:



2. Set the "YFCT" parameter to "turn" using the  button. Display:



3. Switch to the second parameter by briefly pressing the  button. Display:



Note that the transmission ratio selector must be in the 90° position.



4. Press the  button twice to move on to the following display:



The following steps are identical to steps 5 to 8 in the initialisation of linear actuators.

Following successful initialisation, the pivoting range that has been determined is shown on the upper display in degrees.

After briefly pressing the  button, "5.INITM" will appear again in the lower line. You are then once more in the Configuration operating mode.

To leave the Configuration mode, press the  button for longer than 5 s. The software status will be displayed after about 5 s. When the  button is released, the device will be in manual operation mode.

The slip clutch and the transmission ratio selector can be locked if necessary following successful initialisation.

10.3 Copying Initialisation Data (Positioner Exchange)

- Electropneumatic positioners can be exchanged without having to interrupt a running process.
- Through the copying and transferring of device and initialisation data, it is possible to put the replacement positioner into operation without prior initialisation.
- The electropneumatic positioner uses the communication interface for the data transmission.

The following steps are required to exchange a positioner:

1. The device parameters and initialisation data (determined at initialisation time) of the device needing replacement are read in and saved using SIMATIC PDM or HART Communicator. This step is not required if the device has been parameterised with SIMATIC PDM and the data already stored.
2. Fix the positioner in its current position (mechanically or pneumatically).
3. Read and note the current position value from the display of the positioner that is being replaced. If the electronics are faulty, find the current position by measurement at the actuator or valve.
4. Dismount the positioner. Fit the lever arm of the positioner to the replacement device. Mount the replacement device to the fittings. Put the transmission ratio selector in the same position as on the faulty device. Download the device data and initialisation data from the SIMATIC PDM or the HART communicator.
5. If the actual value displayed does not accord with the value noted from the faulty positioner, set the correct value with the slip clutch.

6. The positioner is now ready for operation.

The accuracy and the dynamic behaviour may not be as good as they would be following a proper initialisation. In particular the position of the hard end stops and the associated servicing data may be inaccurate. An initialisation must therefore be carried out at the next opportunity.

ATTENTION

Subsequent initialisation

Initialise the replacement positioner as soon as possible. The following properties are only ensured by the initialisation:

- Optimum matching of the positioner to the mechanical and dynamic properties of the actuator.
- Unrestricted accuracy and unrestricted dynamic behaviour of the positioner.
- Non-deviating positions of the hard stops.
- Correctness of the maintenance data

11 Parameter overview

11.1 Parameters 1 to 5

Parameters 1 to 5 are the same for all versions of the positioner. These parameters are used to match the positioner to the actuator. In the normal case the setting of these parameters is sufficient to be able to operate the positioner on an actuator.

If you wish to learn all the details of the positioner, try out the effects of the other parameters step by step in a targeted fashion.

| Parameters | Function | Parameter values (bold = factory setting) | | | Unit | |
|------------|---|---|---|----------|------|----|
| 1.YFCT | Actuator type | | Normal | Inverted | | |
| | | Rotary actuator | turn | -turn | | |
| | | Linear actuator | WAY | -WAY | | |
| | | Linear actuator without sine correction | LWAY | -LWAY | | |
| | | Rotary actuator with NCS | ncSt | -ncSt | | |
| | | Linear actuator with NCS | ncSL | - ncSL | | |
| | | Linear actuator with NCS and lever | ncSLL | -ncSLL | | |
| 2.YAGL | Nominal rotation angle of the feedback <ul style="list-style-type: none"> Parameter is visible only with "turn" or "WAY"; 33° cannot be set if "turn" is selected. Set the transmission ratio selector accordingly | 33° | | | ° | |
| | | 90° | | | | |
| | | | | | | |
| 3.YWAY | Stroke range (optional setting) <ul style="list-style-type: none"> Parameter appears only with "WAY" and "ncSLL" If used, the value must correspond to the stroke range set on the actuator. The driver pin must be adjusted to the value of the actuator stroke or, if this is not on the scale, to the next largest scaled value. | | | | OFF | |
| | | | 5 10 15 20 (short lever 33°) | | | mm |
| | | | 25 30 35 (short lever 90°) | | | |
| | | | 40 50 60 70 90 110 130 (long lever 90°) | | | |
| | | | | | | |
| 4.INITA | Initialisation (automatic) | NOINI no / ###.# Strt | | | | |
| 5.INITM | Initialisation (manual) | NOINI no / ###.# Strt | | | | |



11.2 Parameters 6 to 52

The following auxiliary functions of the positioner are set with these parameters:

- Setpoint conditioning
- Actual value conditioning
- Binary signal processing

- Sealing function
- Limit value detection

| Parameters | Function | Parameter values (bold = factory setting) | Unit |
|-----------------------|---|--|---------|
| 6.SCUR | Setpoint current range | | |
| | 0 ... 20 mA | 0 mA | |
| | 4 ... 20 mA | 4 mA | |
| 7.SDIR | Setpoint setting | | |
| | Rising | riSE | |
| | Falling | FALL | |
| 8.SPRA | Setpoint split range start | 0.0 ... 100.0 | % |
| 9.SPRE | Setpoint split range end | 0.0 ... 100.0 | % |
| 10.TSUP | Setpoint ramp UP | Auto / 0 ... 400 | s |
| 11.TSDO | setpoint ramp DOWN | 0.0 ... 400 | s |
| 12.SFCT | Setpoint function | | |
| | Linear | Lin | |
| | Equal per-centage | 1 : 25 | 1 - 25 |
| | | 1 : 33 | 1 - 33 |
| | | 1 : 50 | 1 - 50 |
| | Inverse equal percentage | 25 : 1 | n1 - 25 |
| | | 33 : 1 | n1 - 33 |
| | | 50 : 1 | n1 - 50 |
| | Freely adjustable | FrEE | |
| 13.SL0 ... 33.SL20 | Setpoint interpolation point (interpolation points appear only if 12.SFCT = "FrEE" is selected) | | |
| 13.SL0 | at 0 % | | |
| 14.SL1 | 5 % ... | 0.0 ... 100.0 | % |
| | | | |
| 32.SL19 | 95 % | | |
| 33.SL20 | 100 % | | |
| 34.DEBA | Controller dead zone | Auto / 0.1 ... 10.0 | % |
| 35.YA | Control value limitation Start | 0.0 ... 100.0 | % |
| 36.YE | Control value limitation End | 0.0 ... 100.0 | % |
| 37.YNRM | Control value normalisation | | |
| | to mechanical path | MPOS | |
| | to flow | FLOW | |
| 38.YDIR | Direction of action of control value for display and position feedback | | |
| | Rising | riSE | |
| | Falling | FALL | |
| 39.YCLS | Control value - tight closing/- fast closing | | |
| | Without | no | |
| | Tight closing, top | uP | |
| | Tight closing, bottom | do | |

| | | | | |
|-------------------------------|---|---|--|---------------------------------------|
| | Tight closing, top and bottom | uP do | | |
| | Fast closing, top | Fu | | |
| | Fast closing, bottom | Fd | | |
| | Fast closing, top and bottom | Fu Fd | | |
| | Tight closing, top and fast closing, bottom | uP Fd | | |
| | Fast closing, top and tight closing, bottom | Fu do | | |
| 40.YCDO | Value for tight closing below | 0.0 ... 0.5 ... 100 | | % |
| 41.YCUP | Value for tight closing above | 0.0 ... 99.5 ... 100 | | % |
| 42.BIN1 | Function of binary input BE1 | NO contact (action in case of closed switch or high level) | NC contact (action in case of open switch or low level) | |
| | Without | OFF | | |
| | Message only | on | -on | |
| | Block configuration | bloc1 | | |
| | Block configuration and manual | bloc2 | | |
| | Move valve to YE position | uP | -uP | |
| | Move valve to YA position | doWn | -doWn | |
| | Block movement Partial stroke test | StoP PST | -StoP -PST | |
| 43.BIN2 | Function of binary input BE2 | NO contact (action in case of closed switch or high level) | NC contact (action in case of open switch or low level) | |
| | Without | OFF | | |
| | Message only | on | -on | |
| | Move valve to YE position | uP | -uP | |
| | Move valve to YA position | doWn | -doWn | |
| | Block movement | StoP | -StoP | |
| | Partial stroke test | PST | -PST | |
| | 44.AFCT | Alarm function | Normal (High level with no error) | Inverted (Low level with no error) |
| Without A1 = Min, A2 = Max | | OFF  | OFF  | |

| | | | | |
|----------|--|--------------------------------------|---------------------------------------|---|
| | A1 = Min, A2 = Min | | | |
| | A1 = Max, A2 = Max | | | |
| 45.A1 | Response threshold alarm 1 | 0.0 ... 10.0 ... 100 | | % |
| 46.A2 | Response threshold alarm 2 | 0.0 ... 90.0 ... 100 | | % |
| 47.4 FCT | Fault signal output function ("+" means logical OR operation) | Normal (High level with no error) | Inverted (Low level with no error) | |
| | Fault | | | |
| | Fault + not automatic | | | |
| | Fault + not automatic + BE | | | |
| 48.4 TIM | Monitoring time for setting the "control deviation" error message | Auto / 0 ... 100 | | s |
| 49.4 LIM | Response threshold of the "control deviation" error message | Auto / 0 ... 100 | | % |
| 50.PRST | Preset | | | |
| | Resetting of all parameters that can be reset with "Init", "PArA" and "diAg" | ALL | | |
| | Resetting of the initialisation parameters 1.YFCT to 5.INITM. | Init | | |
| | Resetting of the parameters 6.SCUR to 49.LIM. | PArA | | |
| | Resetting of parameters A to P of the extended diagnostic function as well as parameter 52.XDIAG | diAg | | |
| 51.PNEUM | pneumatic type | | | |
| | Standard valve block | Std | | |
| | Fail-in-place valve block | FIP | | |
| | Operation with booster | booSt | | |
| 52.XDIAG | Activation of the extended diagnosis | | | |
| | Parameters A to P are displayed only if the parameter was activated with On1, On2 or On3. The contents of parameters A to P are similarly displayed only if the corresponding parameter was activated by "On". | | | |
| | Off | OFF | | |
| | Single-step message | On1 | | |
| | Two-step message | On2 | | |
| | Three-step message | On3 | | |

11.3 Parameters A to P

The expected diagnostic function of the positioner is set with these parameters.

Parameters A to P and their sub-parameters are displayed only if the extended diagnosis was activated by parameter "XDIAG" with the parameter value "On1", "On2" or "On3".

| Parameters | Function | Parameter value (bold = factory setting) | Unit |
|------------|--|---|------|
| A. ↵ PST | Partial stroke test with the following parameters: | | |
| A1.STPOS | Start position | 0.0 ... 100.0 | % |
| A2.STTOL | Start tolerance | 0.1 ... 2.0 ... 10.0 | % |
| A3.STRKH | Travel height | 0.1 ... 10.0 ... 100.0 | % |
| A4.STRKD | Stroke direction | uP / do / uP do | |
| A5.RPMD | Ramp mode | OFF / On | |
| A6.RPRT | Ramp rate | 0.1 ... 1.0 ... 100.0 | %/s |
| A7.FLBH | Behaviour after failed PST | Auto / Hold / AirIn / AirOu | |
| A8.INTRV | Test interval | OFF / 1 ... 365 | d |
| A9.PSTIN | Partial stroke test reference jump time | NOINI / (C)###.# / Fdini / rREAL | s |
| AA.FACT1 | Factor 1 | 0.1 ... 1.5 ... 100.0 | |
| Ab.FACT2 | Factor 2 | 0.1 ... 3.0 ... 100.0 | |
| AC.FACT3 | Factor 3 | 0.1 ... 5.0 ... 100.0 | |
| b. ↵ DEVI | General valve error with the following parameters: | | |
| b1.TIM | Time constant | Auto / 1 ... 400 | s |
| b2.LIMIT | Limit value | 0.1 ... 1.0 ... 100.0 | % |
| b3.FACT1 | Factor 1 | 0.1 ... 5.0 ... 100.0 | |
| b4.FACT2 | Factor 2 | 0.1 ... 10.0 ... 100.0 | |
| b5.FACT3 | Factor 3 | 0.1 ... 15.0 ... 100.0 | |
| C. ↵ LEAK | Pneumatic leak with the following parameters: | | |
| C1.LIMIT | Limit value | 0.1 ... 30.0 ... 100.0 | % |
| C2.FACT1 | Factor 1 | 0.1 ... 1.0 ... 100.0 | |
| C3.FACT2 | Factor 2 | 0.1 ... 1.5 ... 100.0 | |
| C4.FACT3 | Factor 3 | 0.1 ... 2.0 ... 100.0 | |
| d. ↵ STIC | Static friction (stick-slip effect) with the following parameters: | | |
| d1.LIMIT | Limit value | 0.1 ... 1.0 ... 100.0 | % |
| d2.FACT1 | Factor 1 | 0.1 ... 2.0 ... 100.0 | |
| d3.FACT2 | Factor 2 | 0.1 ... 5.0 ... 100.0 | |
| d4.FACT3 | Factor 3 | 0.1 ... 10.0 ... 100.0 | |
| E. ↵ DEBA | Dead-zone monitoring with the following parameters: | | |
| E1.LEVEL3 | Threshold | 0.1 ... 2.0 ... 10.0 | % |
| F. ↵ ZERO | Zero-point shift with the following parameters: | | |
| F1.LEVEL1 | Threshold 1 | 0.1 ... 1.0 ... 10.0 | % |
| F2.LEVEL2 | Threshold 2 | 0.1 ... 2.0 ... 10.0 | % |
| F3.LEVEL3 | Threshold 3 | 0.1 ... 4.0 ... 10.0 | % |
| G. ↵ PEN | Shift of the upper stop with the following parameters: | | |
| G1.LEVEL1 | Threshold 1 | 0.1 ... 1.0 ... 10.0 | % |

| | | | | |
|-----------|--|------------------------------------|-------------|-------|
| G2.LEVEL2 | Threshold 2 | 0.1 ... 2.0 ... 10.0 | | % |
| G3.LEVEL3 | Threshold 3 | 0.1 ... 4.0 ... 10.0 | | % |
| H. ↵ TMIN | Monitoring of the lower limit temperature with the following parameters: | | | |
| H1.TUNIT | Temperature unit | °C | °F | °C/°F |
| H2.LEVEL1 | Threshold 1 | -40 ... -25 ... 90 | -40 ... 194 | |
| H3.LEVEL2 | Threshold 2 | -40 ... -30 ... 90 | -40 ... 194 | |
| H4.LEVEL3 | Threshold 3 | -40 ... 90 | -40 ... 194 | |
| J. ↵ TMAX | Monitoring of the upper limit temperature with the following parameters: | | | |
| J1.TUNIT | Temperature unit | °C | °F | °C/°F |
| J2.LEVEL1 | Threshold 1 | -40 ... 75 ... 90 | -40 ... 194 | |
| J3.LEVEL2 | Threshold 2 | -40 ... 80 ... 90 | -40 ... 194 | |
| J4.LEVEL3 | Threshold 3 | -40 ... 90 | -40 ... 194 | |
| L. ↵ STRK | Monitoring of the path integral with the following parameters: | | | |
| L1.LIMIT | Limit value for the number of direction changes | 1 ... 1E6 ... 1E8 | | |
| L2.FACT1 | Factor 1 | 0.1 ... 1.0 ... 40.0 | | |
| L3.FACT2 | Factor 2 | 0.1 ... 2.0 ... 40.0 | | |
| L4.FACT3 | Factor 3 | 0.1 ... 5.0 ... 40.0 | | |
| O. ↵ DCHG | Monitoring of the direction changes with the following parameters: | | | |
| O1.LIMIT | Limit value for the number of direction changes | 1 ... 1E6 ... 1E8 | | |
| O2.FACT1 | Factor 1 | 0.1 ... 1.0 ... 40.0 | | |
| O3.FACT2 | Factor 2 | 0.1 ... 2.0 ... 40.0 | | |
| O4.FACT3 | Factor 3 | 0.1 ... 5.0 ... 40.0 | | |
| P. ↵ PAVG | Calculation of the average position value with the following parameters: | | | |
| P1.TBASE | Time base of the average value calculation | 0.5h / 8h / 5d / 60d / 2.5y | | |
| P2.STATE | State of the average position value calculation | IdLE / rEF / ###.# / Strt | | |
| P3.LEVEL1 | Threshold 1 | 0.1 ... 2.0 ... 100.0 | | % |
| P4.LEVEL2 | Threshold 2 | 0.1 ... 5.0 ... 100.0 | | % |
| P5.LEVEL3 | Threshold 3 | 0.1 ... 10.0 ... 100.0 | | % |

12 Service and maintenance

Basic safety instructions



⚠ WARNING

Impermissible repair of the device

Repairs may be carried out only by authorised personnel.



⚠ WARNING

Impermissible accessories and impermissible spare parts

Danger of explosion in potentially explosive areas or damage to the device.

- ▶ Use exclusively original accessories and original spare parts.
- ▶ Observe all relevant installation and safety instructions described in the manuals for the device, accessories and spare parts.



⚠ WARNING

Improper connection after maintenance

Danger of explosion in potentially explosive areas or damage to the device

- ▶ Connect the device correctly after maintenance.
- ▶ Close the device after maintenance.

CAUTION

Penetration of moisture into the interior of the device

Damage to the device

- Make sure that no moisture gets into the interior of the device during cleaning and maintenance work.



⚠ CAUTION

Cancelling the key lock

Improper changing of parameters can impair the process safety.

- ▶ Make sure that only authorised personnel cancel the key lock if the device is used for safety applications.



⚠ WARNING

Electrostatic charging

Danger of explosion in potentially explosive areas due to electrostatic charging, which can occur, for example, when cleaning housings with a dry cloth.

- ▶ Prevent electrostatic charging in potentially explosive areas.

**⚠ WARNING****Open housing**

Danger of explosion in potentially explosive areas due to hot components and/or charged capacitors in the interior of the housing.

- ▶ Switch the device off before opening it in a potentially explosive area.

⇒ **Exceptions:** devices of the ignition protection class Intrinsic Safety "Ex i" may also be opened in a potentially explosive area when switched on.

**⚠ WARNING****Dust deposits thicker than 5 mm**

Risk of explosion in potentially explosive areas. The device can heat up as a result of dust deposits.

- ▶ Remove dust deposits that are thicker than 5 mm.

The positioner requires almost no maintenance. Filters are fitted to the pneumatic connections to protect the positioner against large particles of dirt. Dirt present in the input air can collect on the filter and then adversely affect the operation of the positioner (increased travel time). In such a case, the filters can be cleaned as follows:

1. Switch off the auxiliary pneumatic energy and disconnect the hose lines.
2. Carefully remove the metal filters from the holes and clean them (e.g. with compressed air).
3. Insert the filters.
4. Connect the hose lines again and turn on the auxiliary pneumatic power.

13 Technical Data

General data for the base device

| | |
|-----------------------|--|
| Protection class | IP66 in accordance with EN 60529 |
| Climate class | according to IEC 721 |
| Storage | 1K5 but -40 °C to +80 °C ¹⁾ |
| Transport | 2K4 but -40 °C to +80 °C ¹⁾ |
| Operation | 4K3 but -30 °C ³⁾ to +80 °C ²⁾ (Standard + FIP) 4K3 but -40 to +80 °C (LT) ²⁾ |
| Shock resistance | 10 g to 100 Hz Recommended continuous operation range of the complete valve ≤ 30 m/s ² |
| CE mark | The relevant directives and applied standards with their issue dates can be found in the EC declaration of conformity. |
| Installation position | Any, although in wet environments the pneumatic connections and exhaust opening must not face upwards |
| Connections | |
| electrical | Screw terminals 2.5 AWG28-12 Cable gland M20x1.5 or Cable gland 1/2 –14 NPT |
| pneumatic | Internal thread G 1/4 DIN 45141 or Internal thread 1/4 –18 NPT |

1) If commissioning takes place at ≤ 0 °C it is important that the valves are flushed for long enough with a dry medium.

2) See the electrical data for devices protected against explosion hazard.

3) Restricted refresh rate of the LCD display from -10 °C.

Pneumatic data for the base device

| | |
|------------------------------|---|
| Auxiliary power (air supply) | |
| Medium | Instrument-quality air according to DIN ISO 8573-1, class 2 |
| Pressure | 1,4...7 bar (Standard) / 3...7 bar (FIP) |

Electrical data for the base device

| | Type 827A.E | Type 827A.X |
|---------------------------|------------------|--|
| Ignition protection class | - | II2G Ex ia IIC T4/T6 Gb ¹⁾ |
| Intrinsically safety | | |
| Ambient temperature | - 30 ... + 80 °C | T4 -30 ...+80 °C (Standard + FIP) T6 -30 ...+60 °C (Standard + FIP) T4 -40 ...+80 °C (LT) T6 -40 ...+60 °C (LT) |

1) Limited to T4 on type 827A.X*-A*** with analog module.

| 2-wire connection without HART | Type 827A.E | Type 827A.X |
|---|--|--|
| Current input I_w | 4 ... 20 mA | |
| Current to maintain the auxiliary power | ≥ 3.6 mA | |
| Required load voltage U_B | ≥ 6.5 V ($\approx 325 \Omega$) | ≥ 8.3 V ($\approx 415 \Omega$) |
| Static destruction limit | ± 40 mA | - |
| Internal capacitance C_i | - | 11 nF |
| Internal inductance L_i | - | 207 μ H |
| for connection to electrical circuits with the following maximum values | - | $U_i = DC 30$ V $I_i = 100$ mA $P_i = 1$ W |
| Binary input BE1 (electrically connected to the I_w circuit) | Usable for zero-potential contact Max. contact load $\leq 5 \mu$ A at 3 V | |
| 2-wire connection with HART | Type 827A.E | Type 827A.X |
| Current input J_w | 4 ... 20 mA | |
| Current to maintain the auxiliary power | ≥ 3.6 mA | |
| Required load voltage U_B | ≥ 6.7 V ($\approx 340 \Omega$) | ≥ 8.8 V ($\approx 440 \Omega$) |
| Static destruction limit | ± 40 mA | - |
| Internal capacitance C_i | - | 11 nF |
| Internal inductance L_i | - | 310 μ H |
| for connection to electrical circuits with the following maximum values | - | $U_i = DC 30$ V $I_i = 100$ mA $P_i = 1$ W |
| Binary input BE1 (electrically connected to the I_w circuit) | Usable for zero-potential contact Max. contact load $\leq 5 \mu$ A at 3 V | |
| 3/4-wire circuit with/without HART | Type 827A.E | Type 827A.X |
| Auxiliary voltage U_H | DC 18...35 V | DC 18...30 V DC |
| Current consumption I_{CH} | $I_H [mA] = (U_H [V] - 7.5 V) / 2.4 k\Omega$ | |
| Static destruction limit | ± 35 V | - |
| Internal capacitance C_i | - | 11 nF |
| Internal inductance L_i | - | 310 μ H |

| | | |
|---|---|--|
| for connection to electrical circuits with the following maximum values | - | $U_i = DC\ 30\ V$ $I_i = 100\ mA$ $P_i = 1\ W$ |
| Current input I_{WV} | 0 to 20 mA or 4 to 20 mA | |
| Required load voltage U_B | $\geq 0.2\ V\ (\approx 10\ \Omega)$ | $\geq 1.0\ V\ (\approx 50\ \Omega)$ |
| Static destruction limit | $\pm 40\ mA$ | - |
| Internal capacitance C_i | - | 11 nF |
| Internal inductance L_i | - | 310 μH |
| for connection to electrical circuits with the following maximum values | - | $U_i = DC\ 30\ V$ $I_i = 100\ mA$ $P_i = 1\ W$ |
| Electrical isolation | between U_H and I_W | between U_H and I_W (2 intrinsically safe circuits) |
| Test voltage | DC 840 V, 1 s | |
| Binary input BE1 (electrically connected to the I_W circuit) | Usable for zero-potential contact Max. contact load $\leq 5\ \mu A$ at 3 V | |

Electrical Data for the Options

| | |
|---------------------------|------------------------------|
| Ignition protection class | As base device ¹⁾ |
| Ambient temperature | As base device ¹⁾ |

1) Refer also to the electrical data for the basic device if options with the same ignition protection class as the base device are used.

| Analog module | Type 827A.E | Type 827A.X |
|---|---|--|
| Nominal signal range I_Y | 4 to 20 mA, short-circuit proof | |
| Output range | 3.6 ... 20.5 mA | |
| Auxiliary voltage U_H | DC 12 ... 35 V | DC 12 ... 30 V |
| external load R_B | $R_B [k\Omega] \leq (U_H [V] - 12\ V) / J_Y [mA]$ | |
| Conversion error | $\leq 0.3\ \%$ | |
| Temperature influence | $\leq 0.1\ \% / 10\ K$ | |
| Resolution | $\leq 0.1\ \%$ | |
| Residual ripple | $\leq 1\ \%$ | |
| Internal capacitance C_i | - | 11 nF |
| Internal inductance L_i | - | negligible |
| for connection to electrical circuits with the following maximum values | - | $U_i = DC\ 30\ V$ $I_i = 100\ mA$ $P_i = 1\ W$ |

| | | |
|---|---|---|
| Electrical isolation | To base device | I_V (tml. 61/62) and the base device are individual, intrinsically safe electrical circuits |
| Test voltage | DC 840 V, 1 s | |
| Binary module | Type 827A.E | Type 827A.X |
| Binary outputs A1, A2, I₁ | | |
| Signal state high (not activated) | conducting $R = 1 \text{ k}\Omega^{+3\% / -1\%}$ | $\geq 2.1 \text{ mA}^{2)}$ |
| Signal state low (activated) ³⁾ | blocked $I_R < 60 \text{ mA}$ | $\leq 1.2 \text{ mA}^{2)}$ |
| Internal capacitance C_i | - | 5.2 nF |
| Internal inductance L_i | - | negligible |
| Auxiliary voltage U_H | $\leq \text{DC } 35 \text{ V}$ | - |
| for connection to electrical circuits with the following maximum values | - | $U_i = \text{DC } 15 \text{ V}$ $I_i = 25 \text{ mA}$ $P_i = 64 \text{ mW}$ |
| Binary input BE2 | | |
| Terminal 21/22 (electrically connected to base device) | Usable for zero-potential contact Max. contact load $\leq 5 \mu\text{A}$ at 3 V | |
| Terminal 11/12 (electrically isolated) | | |
| Signal state 0 | $\leq \text{DC } 4.5 \text{ V}$ or open | |
| Signal state 1 | $\geq \text{DC } 13 \text{ V}$ | |
| Input resistance | $\geq 25 \text{ k}\Omega$ | |
| Static destruction limit | $\pm 35 \text{ V}$ | - |
| Internal capacitance C_i | - | negligible |
| Internal inductance L_i | - | negligible |
| for connection to electrical circuits with the following maximum values | - | $U_i = \text{DC } 25.2 \text{ V}$ |
| Electrical isolation | A1, A2, I ₁ , BE2 (tml. 11/12) from one to another and to the basic device | A1, A2, I ₁ , BE2 (tml. 11/12) and the basic device are individual, intrinsically safe electrical circuits |
| Test voltage | DC 840 V, 1 s | |

2) Switching thresholds in case of supply according to DIN EN 60947-5-6 (formerly DIN 19234): $U_H = 8.2 \text{ V}$; $R_i = 1 \text{ k}\Omega$.

3) Low is also the state adopted if the base device is damaged or has no auxiliary electrical power.

| | | |
|-----------------------------------|--|-------------|
| Slot-type initiator module | Type 827A.E | Type 827A.X |
| Binary outputs A1, A2 | | |
| Slot-type initiators | Type SJ2-SN or N7S20A, 2-wire connection, NC contact function (NC) | |

| Connection | to switching amplifier DIN EN 60947-5-6 (formerly DIN 19234) | |
|---|--|---|
| Internal capacitance C_i | - | 161 nF |
| Internal inductance L_i | - | 120 μ H |
| for connection to electrical circuits with the following maximum values | $U_{Nom} = 8$ V | $U_i = DC$ 15 V $I_i = 25$ mA $P_i = 64$ mW |
| Binary output I_1 | | |
| Signal state high (not activated) | $R = 1.1$ k Ω | ≥ 2.1 mA ¹⁾ |
| Signal state low (activated) ²⁾ | $R = 10$ k Ω | ≤ 1.2 mA ¹⁾ |
| Internal capacitance C_i | - | 5.2 nF |
| Internal inductance L_i | - | negligible |
| Auxiliary voltage U_H | $\leq DC$ 35 V | - |
| for connection to electrical circuits with the following maximum values | - | $U_i = DC$ 15 V $I_i = 25$ mA $P_i = 64$ mW |
| Electrical isolation | A1, A2, I_1 from one to another and to the basic device | A1, A2, I_1 and the basic device are individual, intrinsically safe electrical circuits |
| Test voltage | DC 840 V, 1 s | |

1) Switching thresholds in case of supply according to DIN EN 60947-5-6 (formerly DIN 19234): $U_H = 8.2$ V; $R_i = 1$ k Ω .

2) Low is also the state adopted if the base device is damaged or has no auxiliary electrical power.

| Contact module | Type 827A.E | Type 827A.X |
|---|------------------------------|---|
| Binary outputs A1, A2 | | |
| Limit signalling device | mechanical switching contact | |
| max. switching voltage | AC 250 V / DC 24 V- | DC 30 V |
| max. switching current | 4 A | - |
| Internal capacitance C_i | - | negligible |
| Internal inductance L_i | - | negligible |
| for connection to electrical circuits with the following maximum values | - | $U_i = DC$ 30 V $I_i = 100$ mA $P_i = 750$ mW |
| Binary output I_1 | | |
| Signal state high (not activated) | $R = 1.1$ k Ω | ≥ 2.1 mA ¹⁾ |
| Signal state low (activated) ²⁾ | $R = 10$ k Ω | ≤ 1.2 mA ¹⁾ |
| Internal capacitance C_i | - | 5.2 nF |

| | | |
|---|---|---|
| Internal inductance L_i | - | negligible |
| Auxiliary voltage U_H | \leq DC 35 V | - |
| for connection to electrical circuits with the following maximum values | - | $U_i =$ DC 15 V $I_i =$ 25 mA $P_i =$ 64 mW |
| Electrical isolation | A1, A2, I_1 from one to another and to the basic device | A1, A2, I_1 and the basic device are individual, intrinsically safe electrical circuits |
| Test voltage | DC 3150 V, 2 s | |

1) Switching thresholds in case of supply according to DIN EN 60947-5-6 (formerly DIN 19234): $U_H = 8.2$ V; $R_i = 1$ k Ω .

2) Low is also the state adopted if the base device is damaged or has no auxiliary electrical power.

14 Fault removal

Diagnostic guide

| | See Table | | | |
|--|-----------|---|---|---|
| In which operating mode does the fault appear? | | | | |
| ▪ Initialisation | 1 | | | |
| ▪ Manual operation and automatic operation | 2 | 3 | 4 | 5 |
| In what environment and under what boundary conditions does the fault appear? | | | | |
| ▪ Wet environment (e.g. severe rain or constant condensation) | 2 | | | |
| ▪ Vibrating (oscillating) fittings | 2 | 5 | | |
| ▪ Impact or shock loading (e.g. "steam hammer" or breakaway flaps) | 5 | | | |
| ▪ Damp (wet) compressed air | 2 | | | |
| ▪ Dirty compressed air (contaminated with solid particles) | 2 | 3 | | |
| When does the fault appear? | | | | |
| ▪ Regularly (reproducible) | 1 | 2 | 3 | 4 |
| ▪ Sporadically (not reproducible) | 5 | | | |
| ▪ Mostly after a certain length of time of operation | 2 | 3 | 5 | |

Table 1

| Fault symptoms | Possible cause(s) | Remedial measures |
|--|---|--|
| Positioner remains in "RUN 1" mode. | <ul style="list-style-type: none"> ▪ Initialisation started from end position and ▪ failure to wait for reaction time of max. 1 min. ▪ Mains pressure not connected or too low. | <ul style="list-style-type: none"> ▪ up to 1 min waiting time is required ▪ Do not start initialisation from end position ▪ Check mains pressure |
| Positioner remains in "RUN 2" mode. | <ul style="list-style-type: none"> ▪ Transmission ratio selector and parameter 2 "YAGL" and the real stroke do not correspond. ▪ Stroke on lever incorrectly adjusted. ▪ Piezo valve(s) are not switching (see Table 2). | <ul style="list-style-type: none"> ▪ Check settings: transmission ratio selector and parameter 2 ▪ Check stroke adjustment on lever. ▪ See Table 2. |
| Positioner remains in "RUN 3" mode. | <ul style="list-style-type: none"> ▪ Actuator travel time too long | <ul style="list-style-type: none"> ▪ Open restrictor completely and/or set P_z pressure to highest permissible value. ▪ If necessary use booster. |
| Positioner remains in "RUN 5" mode, does not get to "FINISH" (waiting time > 5 min). | <ul style="list-style-type: none"> ▪ Slack (play) in the positioner - actuator - fitting system | <ul style="list-style-type: none"> ▪ Rotary actuator: Check that grub screw on the coupling wheel is tight. ▪ Linear actuator: Check that lever on the positioner shaft is tight. ▪ Remove any other play between actuator and fitting. |

Table 2



| Fault symptoms | Possible cause(s) | Remedial measures |
|---|--|--|
| <ul style="list-style-type: none"> ▪ “CPU test” flashes in the display (approx. every 2 s) ▪ Piezo valve(s) is/are not switching. | <ul style="list-style-type: none"> ▪ Water in the valve block (caused by wet compressed air) | <ul style="list-style-type: none"> ▪ In its early stages the fault can be removed by subsequent operation with dry air (if necessary in the dryer at 50 to 70 °C) |
| <ul style="list-style-type: none"> ▪ Actuator will not move at all or only in one direction in both manual and automatic operating modes. | <ul style="list-style-type: none"> ▪ Dampness in the valve block | <ul style="list-style-type: none"> ▪ otherwise repair |
| <ul style="list-style-type: none"> ▪ Piezo valve(s) is/are not switching (also, no soft "clicking" is audible if the  or  button is depressed in manual operating mode). | <ul style="list-style-type: none"> ▪ Screw between the basic electronics and the valve block is not tight. | <ul style="list-style-type: none"> ▪ Tighten the screws |
| | <ul style="list-style-type: none"> ▪ Dirt (chips, particles) in valve block | <ul style="list-style-type: none"> ▪ Repair or new unit |
| | <ul style="list-style-type: none"> ▪ Deposits on contacts between electronics board and valve block; these can occur as a result of abrasion from long-term loading caused by severe vibration. | <ul style="list-style-type: none"> ▪ clean all contact surfaces with spirit, if necessary bend valve block contact springs a little. |

Table 3



| Fault symptoms | possible cause(s) | Remedial measures |
|---|---|---|
| <ul style="list-style-type: none"> ▪ Actuator does not move | <ul style="list-style-type: none"> ▪ Compressed air < 1.4 bar | <ul style="list-style-type: none"> ▪ Set incoming air pressure to > 1.4 bar. |
| <ul style="list-style-type: none"> ▪ Piezo valve(s) is/are not switching (however, a soft "clicking" is audible if the  or  button is depressed in manual operating mode). | <ul style="list-style-type: none"> ▪ Restrictor valve(s) closed (screw(s) at the clockwise stop) | <ul style="list-style-type: none"> ▪ Open restrictors by turning counter-clockwise |
| | <ul style="list-style-type: none"> ▪ Dirt in the valve block | <ul style="list-style-type: none"> ▪ Repair or new unit |
| <ul style="list-style-type: none"> ▪ In steady-state automatic operating mode (constant setpoint) and in manual operating mode one piezo valve is constantly switching. | <ul style="list-style-type: none"> ▪ Pneumatic leakage in the positioner - actuator system. Begin leakage test in “RUN 3” (initialisation) | <ul style="list-style-type: none"> ▪ Remove source of leakage in actuator and/or feed ▪ in the case where actuator is intact and feed is fully sealed: Repair or new unit |
| | <ul style="list-style-type: none"> ▪ Dirt in the valve block (see above) | <ul style="list-style-type: none"> ▪ Repair or new unit |

Table 4

| Fault symptoms | possible cause(s) | Remedial measures |
|---|---|---|
| <ul style="list-style-type: none"> ▪ In steady-state automatic operating mode (constant setpoint) and in manual operating mode both piezo valves are constantly switching alternately; actuator oscillates about a mean value. | <ul style="list-style-type: none"> ▪ Static friction in the stuffing box of fitting or actuator too large. | <ul style="list-style-type: none"> ▪ Reduce static friction or increase dead zone (parameter DEbA) until the oscillating movement stops. |
| | <ul style="list-style-type: none"> ▪ Clearance in the system ▪ positioner - actuator - valve | <ul style="list-style-type: none"> ▪ Rotary actuator: Check that grub screw on the coupling wheel is tight |

| | | |
|--|---|---|
| | | <ul style="list-style-type: none"> ▪ Linear actuator: Check that lever on the positioner shaft is tight. ▪ Remove any other play between actuator and fitting. |
| | <ul style="list-style-type: none"> ▪ Actuator too fast | <ul style="list-style-type: none"> ▪ Increase travel times by means of restrictor screws. ▪ If fast travel time is necessary, increase dead zone (parameter DEbA) until the oscillating movement stops. |
| <ul style="list-style-type: none"> ▪ Positioner does not drive fitting up to the stop (with a 100 % input signal) | <ul style="list-style-type: none"> ▪ Supply pressure too low | <ul style="list-style-type: none"> ▪ Increase supply pressure |
| | <ul style="list-style-type: none"> ▪ Load voltage of the supply controller or system output is too low | <ul style="list-style-type: none"> ▪ Interpose load transformer ▪ Select 3/4-wire operation |

Table 5

| Fault symptoms | possible cause(s) | Remedial measures |
|---|--|--|
| <ul style="list-style-type: none"> ▪ Null point moves about sporadically (> 3 %). | <ul style="list-style-type: none"> ▪ As a result of impact or shock loading accelerations occur that are so high that the slip clutch is displaced (e.g. by "steam hammer" in steam pipework) | <ul style="list-style-type: none"> ▪ Remove causes of shock loading. ▪ Re-initialise positioner, lock slip clutch and transmission ratio selector (see sections 4.5.1 and 4.5.2) |
| <ul style="list-style-type: none"> ▪ No device function at all, also no display | <ul style="list-style-type: none"> ▪ electrical auxiliary power source inadequate (< 3.6 mA) | <ul style="list-style-type: none"> ▪ check electrical auxiliary power source. |
| | <ul style="list-style-type: none"> ▪ In case of very high long-term loading caused by vibration (oscillations): | |
| | <ul style="list-style-type: none"> ▪ screws of the electrical connecting terminals can work loose ▪ electrical connecting terminals and/or electronic components can be shaken loose | <ul style="list-style-type: none"> ▪ Tighten screws and secure with sealant. ▪ Repair ▪ for prevention: mount positioner on rubber-metal mounts |



15 Disposal and recycling

WARNING

Operating media and auxiliary materials that are hazardous to health

Danger to people and the environment!

- ▶ Wear suitable protective equipment
- ▶ If applicable, collect and dispose of rinsing medium or residual medium. Particular attention is to be paid to dead spaces (pressure compensation, bellows, etc.)
- ▶ Observe the legal regulations for the disposal of media that are hazardous to health

ARCA products are modularly constructed and can be sorted by material into the following components.

- Electronic components
- Metals
- Plastics
- Greases and oils
- Packaging material

The general rules are:

- greases and oils are usually water pollutants and must not be allowed to escape into the environment
- Dispose of dismantled materials properly or recycle the separate materials
- Observe national disposal regulations



**Valve
& Automation**
Total Valve & Control Solutions®

JOHANNESBURG
Tel: 011 397 2833

DURBAN
Tel: 031 579 2593

South Africa:
0861 103 103

E-mail: sales@valve.co.za
www.valve.co.za

