

Stafsjö
SINCE 1666

HG



STAFSJÖ
1300250
14408



V&A

*Data is only for informational purpose.
All specifications are subject to change without notice.*

First in knife gate solutions

Knife gate valve HG

Stafsjö's HG is a through-going knife gate valve with superior flow characteristics, offering reliable bi-directional zero leakage shut-off on highly concentrated media and static media columns. It can operate on different media such as pulp stock up to 18 % concentrations, slurry, liquor, ash and granulate. It is also widely used in junc traps, mostly as inlet valve with our RKO as discharge valve.

The HG valve is modular designed and it can easily be customized in materials, with actuators and related automation accessories to different process conditions. The valve has a rigid two piece precision machined valve body with a high strength top works that provide an essential and precise gate alignment. As standard it is available with a valve body in stainless steel or nodular iron, but it can also be supplied in a range of high alloy materials such as Duplex and 254 SMO.

The HG valve is one out of five of Stafsjö's through-going knife gate valves. The HP is a high pressure version of HG while the HL is a slim line version. HPT is a high pressure version entirely made in Titanium and the HX is an extreme high pressure version.

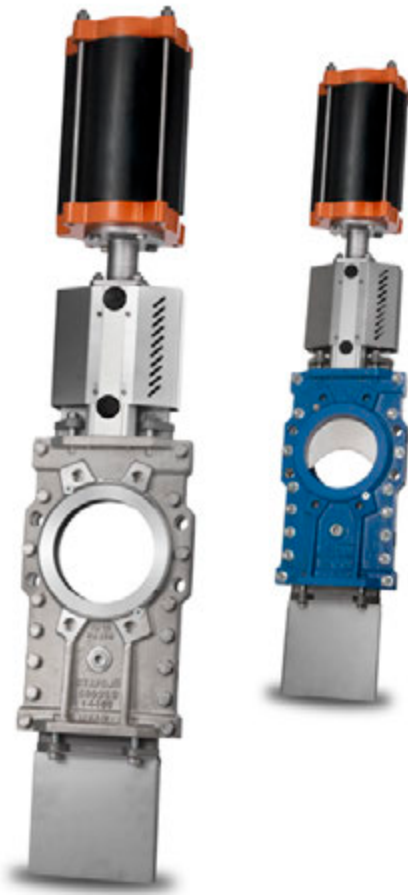

Product features



Full bore with outstanding flow characteristics

While the HG is in open position you have an unobstructed flow path where no media can collect. The PTFE seats (1) are protected by the gate (2) and retainers (3) and the internal back-up o-rings (4) keep the seats constantly pressurized against the gate. Polyurethane retainers/seats is an option for abrasive processes while the metal only is an extreme high temperature option.

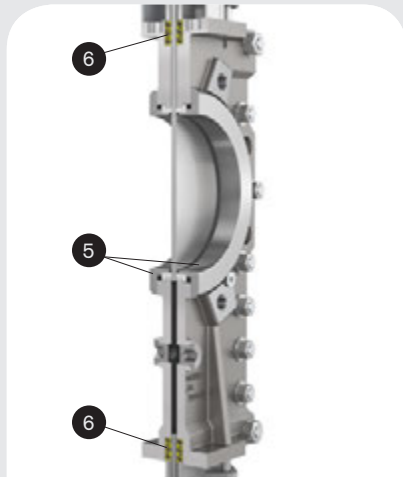

Reliable through-going and bi-directional zero leakage shut-off

The gate is guided throughout the entire stroke and operates smoothly through difficult and highly concentrated media. The retainer ring system (5) on both side of the gate provide a tight seal independent of pressure direction. The gland box sealing system with three layers of Stafsjö's Twin-Pack (6) ensures that no media reaches the surrounding environment. Extra scrapers or double gland can be used for the most demanding services.



The retainer ring system extend service life and makes it easy to process customize HG

The retainers (7) hold the seats (8) and the back-up o-rings (9) in exact correct position as the gate strokes. They are mechanically locked and can easily be removed for seat change. Both the retainers and seats are available in different materials which makes it easy to customize HG to different process conditions.

Pressure class

Max working pressure at 20 °C		Max differential pressure at 20 °C	
DN	bar	DN	bar
80 - 250	10	80 - 250	10
300 - 800	6	300 - 800	6
900 - 1200	4	900 - 1200	4

HG configurations

Standard in stainless steel

Sizes: DN 80 - DN 1200

Valve body: Stainless steel EN 1.4408

Retainer rings: Stainless steel EN 1.4408

Gate: Stainless steel EN 1.4404, AISI 316L

Box packing: TwinPack

Top works: Stainless steel tie rods encapsulated in aluminum beams up to DN 1000 and stainless steel beams on larger ones including stainless steel gate guards on automated valves

Seat, actuator, flange drilling and accessories available from options below

Standard in nodular iron

Sizes: DN 80 - DN 600

Valve body: Nodular iron EN 5.3105

Retainer rings: Nodular iron EN 5.3105, EN-JS1050, GGG50

Gate: Stainless steel EN 1.4404, AISI 316L

Box packing: TwinPack

Top works: Stainless steel tie rods encapsulated in aluminum beams including stainless steel gate guards on automated valve

Seat, actuator, flange drilling and accessories available from options below

Options

Valve body¹⁾

Stainless steel EN 1.4408 (Max +400 °C)

Nodular iron EN 5.3105 (Max +350 °C)

Duplex stainless steel EN 1.4470 (Max +250 °C)

254 SMO Stainless steel (Max +399 °C)

Retainer rings

Stainless steel EN 1.4408

Nodular iron EN 5.3105, EN-JS1050, GGG50

Duplex stainless steel EN 1.4470

254 SMO stainless steel

Polyurethane

Gate material and surface treatments

Stainless steel EN 1.4404, AISI 316L

Duplex stainless steel EN 1.4462, S32205

254 SMO stainless steel

Hard chromed surface

Extra polished surface (max Ra 0,8)

Seats

PTFE with o-ring in Nitrile, EPDM or FKM

FDA/EC 1935/2004 approved PTFE

Polyurethane

Stainless steel metal seat with grafoil tape or o-rings in Nitrile, EPDM or FKM

Box packings

TwinPack, WhitePack, Graphite or FDA/EC 1935/2004 approved PTFE

Extra scrapers in UHMW-PE, PTFE or brass

Top works

Stainless steel tie rods encapsulated in aluminum beams

Stainless steel pillars²⁾ or beams

Actuators

Hand wheel with non-rising stem

Chain wheel

Bevel gear

Double-acting pneumatic cylinders

Single-acting pneumatic cylinders

Electric actuators

Hydraulic actuator

Flange drillings

EN 1092 PN 10

EN 1092 PN 16

ASME/ANSI B16.5 Class 150 and B16.47 Class 150, series A

JIS B 2238 10K

AS 2129 Table D and E

BS 10 Table D

Accessories

Limit switches, solenoid valves, positioners, mechanical lockouts, V-port, double gland, stem extensions etc. See Stafsjö's accessory data sheet for further information.

¹⁾ The valve body is as standard supplied with purge ports from DN 100: G1/2"

²⁾ Standard on valves supplied with valve body in Duplex or 254 SMO

Design standards

Face-to-face dimensions

Stafsjö manufacturing standard. Option in MSS-SP81.

Design, manufacturing, inspection and test

According to pressure equipment directive 2014/68/EU category I and II module A2. The valves are CE marked when it is applicable.

Stafsjö's valves are subject for pressure tests before delivery in opened and closed position with water at 20 °C according to EN 12266-1:2009 rate A. No visually detectable leakage is allowed for duration of the test. Rate A is not applicable on metal seated valves.

On request 2.2 test report and 3.1 inspection certificate according to EN 10204.

Corrosion protection

Non-corrosive resistant materials are coated in colour RAL5015 as standard to fulfill the requirements in EN ISO 12944 class C3. Optional coatings include EN ISO 12944 class C4 or C5.

ATEX designs

On request directive 2014/34/EU Group II category:

3 G/D (zone 2 or 22)

2 G/D (zone 1 or 21)

1 D (Zone 20)

Seat service temperatures

PTFE with o-ring Nitrile: -25 °C - +100 °C

PTFE with o-ring EPDM: -25 °C - +120 °C

PTFE with o-ring FKM: -15 °C - +180 °C

Polyurethane: -25 °C - +90 °C

Box packing service temperatures

TwinPack: -60 °C - +260 °C

WhitePack: -60 °C - +260 °C

PTFE: -200 °C - +280 °C

Graphite: -200 °C - +600 °C

Additional scrapers in the gland box

UHMW-PE: -200 °C - +85 °C

PTFE: -80 °C - +260 °C

Brass: -125 °C - +200 °C

Media type, pressure and operating intervals may also affect the seat and box packing material in different ways. Contact Stafsjö for advice.

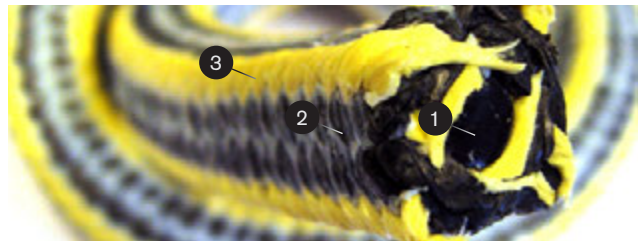

A first rate external sealing with TwinPack

Stafsjö's TwinPack offers high mechanical strength, excellent chemical resistance and a tight seal to atmosphere. The TwinPack braid is made up by an elastic silicon rubber core (1) surrounded by diagonally interlocked graphite filled PTFE (2) with aramid fiber reinforced corners (3). The TwinPack braids resist pH 2-13 and temperatures -60 °C up to 260 °C.

Ideal pulp tower isolation valve

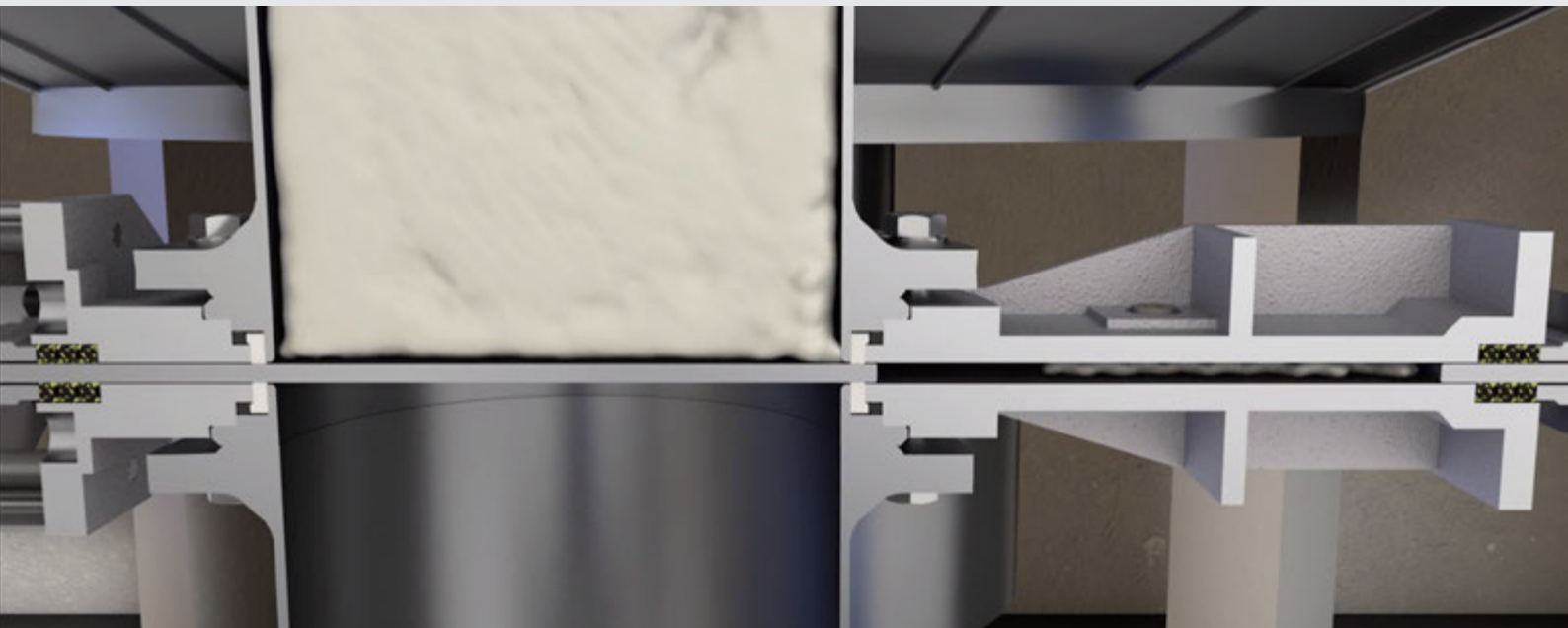

Pulp tower isolations require full bore and cavity free valves to assure a smooth pulp stock feed. It is crucial the valve ensure a safe and tight shut-off to avoid dewatering the pulp stock and at maintenance to guarantee the work can be performed safely on related process equipment. High pulp concentrations in the range 7 - 14 % are common and place special requirements on the knife gate valve. Stafsjö's HG has the technology to master the challenges.

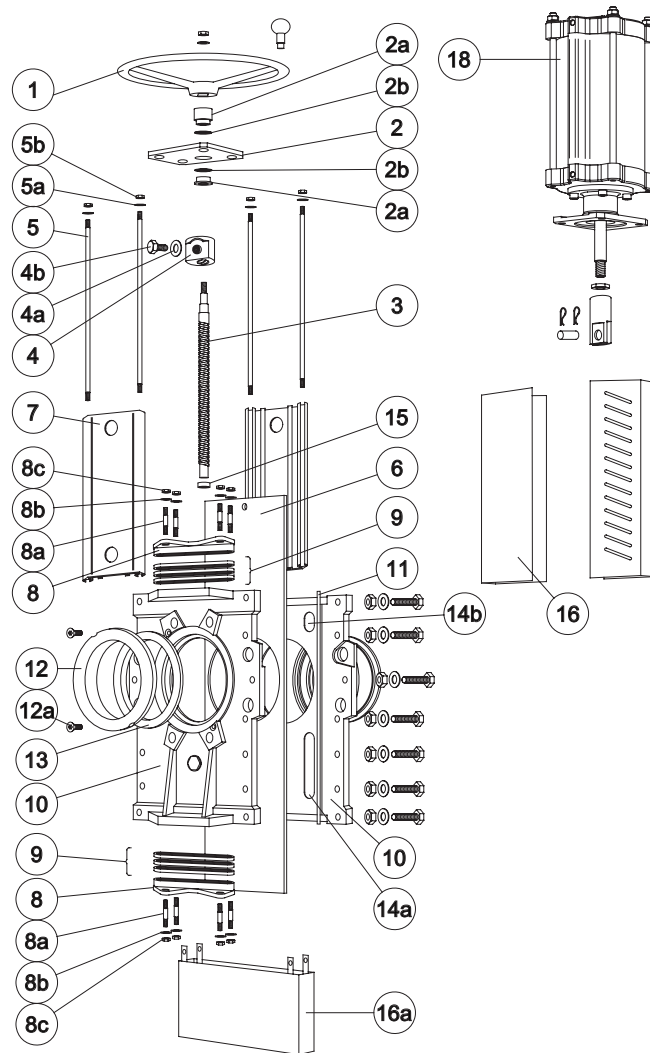

Part list

Pos.	Part	Material
1	Hand wheel	Coated cast iron Ø 200 - Ø 315 EN-JL1040, GG25, ≥ Ø 400 EN-JL1030, GG20
2	Yoke	Stainless steel EN 1.4301
2a	Bearing	Brass CuZn39Pb3
2b	Slide washer	POM
3	Stem	Stainless steel EN 1.4016 alt. EN 1.4305
4	Stem nut	Brass CW603N alt. CW614N
4a	Washer	Stainless steel A2
4b	Screw	Stainless steel A2
5	Tie rod	Stainless steel EN 1.4301
5a	Washer	Stainless steel A2
5b	Nut	Stainless steel A2
6	Gate	See options on page 3
7	Beam	Aluminium EN AW-6063-T6

1) Recommended spare part

Pos.	Part	Material
8	Gland	Stainless steel EN 1.4408 Coated nodular iron EN-JS1050, GGG50, GGG50 on HG-L ≤ DN 300
8a	Stud bolt	Stainless steel A2
8b	Washer	Stainless steel A2
8c	Nut	Stainless steel A2
9 ¹⁾	Box packing	See options on page 3
10	Valve body	See options on page 3
11	Body gasket	Grafoil. DN ≥ 200: PTFE
12	Retainer ring	See options on page 3
12a	Locking screw	Stainless steel A2
13 ¹⁾	Seat	See options on page 3
14a	Guiding pads	Only DN ≥ 250: PTFE
14b	Guiding pads	Only DN ≥ 250: PTFE
15	Bushing	Oil-bronze
16	Gate guards	Stainless steel EN 1.4301
18	Pneumatic cylinder	See separate data sheet

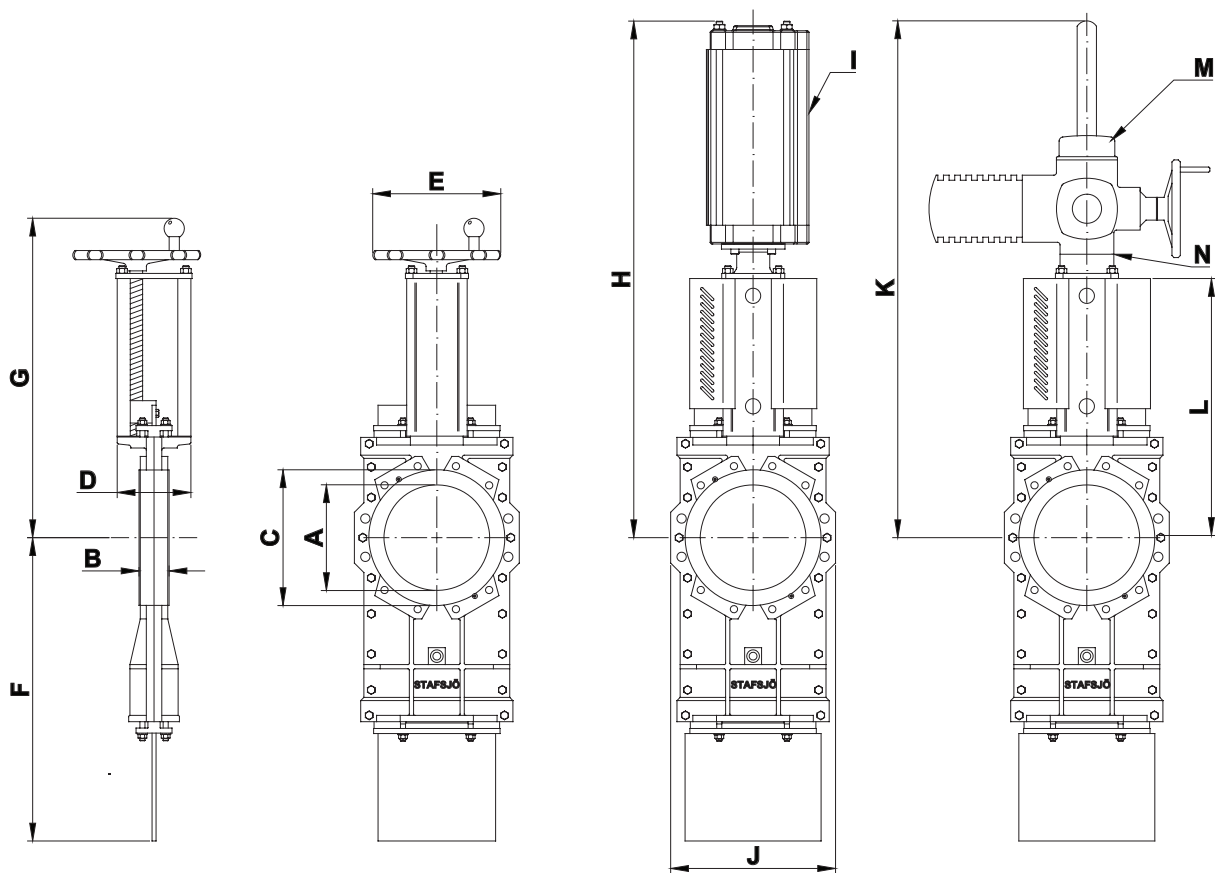

Main dimensions (mm)

DN	A	B	C	D	E	F	G	H	I ¹⁾	J	K	L	M ²⁾	N ³⁾	W ⁴⁾
80	79	51	125	70	200	285	405	549	SC100	180	744	275	SA07.2	F10/A	17
100	103	51	153	72	200	385	445	614	SC100	210	809	315	SA07.2	F10/A	22
125	128	56	179	80	250	424	485	753	SC160	240	874	355	SA07.2	F10/A	29
150	153	60	205	80	250	455	530	823	SC160	260	944	400	SA07.6	F10/A	34
200	202	60	270	150	315	600	659	974	SC160	330	1070	520	SA07.6	F10/A	75
250	250	69	320	150	315	725	739	1109	SC160	390	1200	600	SA07.6	F10/A	100
300	302	78	375	180	400	865	893	1332	SC200	455	1420	720	SA10.2	F10/A	170
350	332	78	425	175	400	980	948	1417	SC200	510	1505	775	SA10.2	F10/A	200
400	380	89	480	210	520	1070	1033	1585	SC200	570	1650	873	SA10.2	F10/A	290
450	428	89	534	220	520	1210	1124	1790	SC250	625	1790	963	SA10.2	F10/A	410
500	470	114	580	320	635	1412	1299	1990	SC250	690	2020	1138	SA14.2	F14/A	670
600	540	122	679	350	635	1553	1336	2113	SC320	800	2135	1175	SA14.2	F14/A	820
700	665	128	800	320	635	1891	1556	2458	SC320	995	2505	1395	SA14.6	F14/A	1300
800	760	128	900	320	635	2132	1721	2723	SC320	1070	2770	1560	SA14.6	F14/A	1700
900	880	128	1009	310	-	2467	-	3018	SC320	1168	3026	1740	-	-	-
1000	980	150	1110	310	-	2710	-	3328	SC320	1270	3320	1935	-	-	-
1200	1200	150	1334	505	-	3339	-	-	-	1500	4222	2485	-	-	-

1) Recommended sizing of double-acting pneumatic cylinder type SC at normal operation with 5 bar air pressure. For other operating conditions, contact Stafsjö or your local representative for advice.

2) Recommended sizing of Auma SA electric motors at normal operation. For other operating conditions, contact Stafsjö or your local representative for advice.

3) Valve and Auma SA interface. The electric motors are mounted as standard according to ISO 5210 connection A (rising stem).

7) Weight in kg for valve with hand wheel (HW)

Main dimensions are only for information. Contact Stafsjö for certified drawings.

Flange drilling according to EN 1092 PN 10

DN	80	100	125	150	200	250	300	350	400
Bolt circle diameter (mm)	160	180	210	240	295	350	400	460	515
Number of throughgoing bolts	4	4	4	4	4	4	4	4	4
Number of tapped holes/side	4	4	4	4	4	8	8	12	12
Bolt size	M16	M16	M16	M20	M20	M20	M20	M20	M24
Bolt lengths ¹⁾ (mm)	13	13	15	15	16	18	20	20	25

DN	450	500	600	700	800	900	1000	1200
Bolt circle diameter (mm)	565	620	725	840	950	1050	1160	1380
Number of throughgoing bolts	4	4	4	4	4	4	4	4
Number of tapped holes/side	16	16	16	20	20	24	24	28
Bolt size	M24	M24	M27	M27	M30	M30	M33	M36
Bolt lengths ¹⁾ (mm)	25	27	28	28	31	31	38	40

Flange drilling according to EN 1092 PN 16

DN	80	100	125	150	200	250	300	350	400
Bolt circle diameter (mm)	160	180	210	240	295	355	410	470	525
Number of throughgoing bolts	4	4	4	4	4	4	4	4	4
Number of tapped holes/side	4	4	4	4	8	8	8	12	12
Bolt size	M16	M16	M16	M20	M20	M24	M24	M24	M27
Bolt lengths ¹⁾ (mm)	13	13	15	15	16	18	20	20	25

DN	450	500	700	800	900	1000	1200
Bolt circle diameter (mm)	585	650	840	950	1050	1170	1390
Number of throughgoing bolts	4	4	4	4	0	4	4
Number of tapped holes/side	16	16	20	20	28	24	28
Bolt size	M27	M30	M33	M36	M36	M39	M45
Bolt lengths ¹⁾ (mm)	25	27	28	31	31	38	40

Flange drilling according to ASME/ANSI B16.5 & B16.47 Class 150

DN	80	100	125	150	200	250	300	350	400
Bolt circle diameter (mm)	152,4	190,5	215,9	241,3	298,4	361,9	431,8	476,3	539,8
Number of throughgoing bolts	2	4	4	4	4	4	4	4	4
Number of tapped holes/side	2	4	4	4	4	8	8	8	12
Bolt size (UNC)	5/8-11	5/8-11	3/4-10	3/4-10	3/4-10	7/8-9	7/8-9	1-8	1-8
Bolt lengths ¹⁾ (mm)	13	13	15	15	16 ²⁾	18	20	20	25

DN	450	500	600	700	800	900	1000	1200
Bolt circle diameter (mm)	577,9	635	749,3	863,6	977,9	1085,9	1200,2	1422,4
Number of throughgoing bolts	4	4	4	4	4	4	4	8
Number of tapped holes/side	12	16	16	24	24	28	32	36
Bolt size (UNC)	1 1/8-7	1 1/8-7	1 1/4-7	1 1/4-7	1 1/2-6	1 1/2-6	1 1/2-6	1 1/2-6
Bolt lengths ¹⁾ (mm)	25	27	28	28	31	31	38	40

1) Add the values with the thickness of flanges, washers and gaskets.

2) The screws on the seatside has to be 10 mm longer for face-to-face according to MSS-SP81.

OR = On request

Flange drilling according to JIS B 2238 10K

DN	80	100	125	150	200	250	300	350	400
Bolt circle diameter (mm)	150	175	210	240	290	355	400	445	510
Number of throughgoing bolts	4	4	4	4	4	4	4	4	4
Number of tapped holes/side	4	4	4	4	8	8	12	12	12
Bolt size	M16	M16	M20	M20	M20	M22	M22	M22	M24
Bolt lengths ¹⁾ (mm)	13	13	15	15	16	18	20	20	25

DN	450	500	600	700	800	900	1000	1200
Bolt circle diameter (mm)	565	620	730	840	950	1050	1160	1380
Number of throughgoing bolts	4	4	8	4	4	4	4	4
Number of tapped holes/side	16	16	16	20	24	24	24	28
Bolt size	M24	M24	M30	M30	M30	M30	M36	M36
Bolt lengths ¹⁾ (mm)	25	27	28	28	31	31	38	40

Flange drilling according to BS 10 Table D

DN	80	100	125	150	200	250	300	350	400
Bolt circle diameter (mm)	146,1	177,8	209,6	235	292,1	355,6	406,4	469,9	520,7
Number of throughgoing bolts	2	2	4	4	4	4	4	4	4
Number of tapped holes/side	2	2	4	4	4	4	8	8	8
Bolt size	5/8-11	5/8-11	5/8-11	5/8-11	5/8-11	3/4-10	3/4-10	7/8-9	7/8-9
Bolt lengths ¹⁾ (mm)	13	13	15	15	16	18	20	20	25

DN	450	500	600	700	800	900	1000	1200
Bolt circle diameter (mm)	584,2	641,4	755,7	845	984,2	1092,2	1175	OR
Number of throughgoing bolts	4	4	4	4	4	4	4	OR
Number of tapped holes/side	8	12	12	16	16	20	20	OR
Bolt size	7/8-9	7/8-9	1-8	1-8	1 1/4-7	1 1/4-7	1 1/4-7	OR
Bolt lengths ¹⁾ (mm)	25	27	28	28	31	31	38	OR

¹⁾ Add the values with the thickness of flanges, washers and gaskets.
OR = On request



Stafsjö
SINCE 1666

www.stafsjo.com



**Valve
& Automation**

Total Valve & Control Solutions®

JOHANNESBURG

Tel: 011 397 2833

DURBAN

Tel: 031 579 2593

South Africa:

0861 103 103

E-mail: sales@valve.co.za

www.valve.co.za



SCAN ME