

PROCONTROL



SPS & SPD

**single & double acting
pneumatic actuators**

the Premium series



ProControl the Company

ProControl is an independent highly flexible versatile and professional company specializing in the manufacture and supply of complete valve actuation. Our customers can rely on many years of industry experience and dedicated service, our products have been designed to meet tomorrow's requirements in order to achieve maximum efficiency, safety and reliability.

From our factory located in Castell'Arquato, ProControl personnel have built up a sound and strong reputation in being able to supply first class support to our clients, by offering innovative solutions and designs for all applications.

ProControl's talented workforce is also ideally suited to offer clients' purpose built specifically engineered products as well as a standard product range. ProControl technical expertise can offer creative solutions to clients' problems thanks to years of experience from the field and to continual research into new technology.

Our highly trained personnel is committed to meet today's fast response demands, responding rapidly and efficiently to clients requirements from the initial inquiry stage throughout contract handling to final delivery and commissioning.

Our clients can count on first class after sales support thanks to our efficient rapid response after sales service department, which coordinates together with our service support centres located in all key territories around the world. If required, ProControl's highly qualified English speaking service engineers can be deployed from our factory at a moment's notice, and can be onsite anywhere in the world within 24 hours from callout.



ProControl
factory in Aksai,
Kazakhstan





ProControl GMBH
factory in
Landau-Pfalz,
Germany



ProControl srl Headquarter in Italy

factory area m² 8.500

QUARTER TURN

PNEUMATIC ACTUATORS

SINGLE & DOUBLE ACTING

SPS & SPD series



DESCRIPTION

The **SPS** & **SPD** series, heavy duty high performance design actuators, are for ProControl the long-standing products of the range. The reliability and firmness that distinguish them arise from a constant innovation research combined with the experience gained over the years.

KEY FEATURES

- Fabricated entirely from **carbon steel**
- Totally enclosed **weatherproof** housing
- **Scotch yoke mechanism** to suit valve torque requirements
- Relief vent to expel undesired overpressure
- Low pressure pneumatic cylinder for supply pressures up to **12 bar design** suitable for instrument air or sweet / inert gas applications or special application with material according to **NACE** requirements for sour gas supply medium
- **Carbon steel piston** with dynamic floating O-ring seals coupled with lubricating piston guide rings
- **Carbon steel spring cartridge** (only for single acting) with safety facility which allows safe installation and removal of the whole cartridge assembly
- **AISI 316SS mechanical position indicator** (fully sealed **IP68** to avoid ingress into the scotch yoke area) complete with **VDI/VDE 3845 NAMUR** drive slot for monitoring devices
- **Bronze sliding blocks** which ensure minimum friction, allowing for a long service life and reducing maintenance costs
- **Bronze thrust bearings** and **high strength alloy steel chromium plated thrust reaction bar** which guides the scotch yoke throughout its stroke and supports all transverse loads generated
- **ASTM A 320 L7 alloy steel tie rods**, with standard electrolytic zinc coating according to **ASTM B633 FeZn 12** (thickness 12 µm)
- **Alloy steel end travel stops** allow for accurate angular stroke adjustment
- Integral manual override facilities
- **Design allows 4 x 90° actuator rotation**



TECHNICAL SPECIFICATIONS

- Supply pressure up to **12 bar design**
- Actuator torque output up to **1.000.000 Nm** for single acting and up to **2.000.000 Nm** for double acting
- Spring starting torque up to **400.000 Nm**
- Spring ending torque up to **250.000 Nm**
- Standard operating temperature range **-30°C / +100°C**
- Special low temperature application up to **-60°C**
- Special high temperature application up to **+200°C**
- All ProControl pressure containing parts are designed according to customer request: **PED / ASME VIII div.1 and EN 13445**
- All ProControl actuators are designed for **30 years' service life**

SPS & SPD series Quarter Turn

ProControl actuator housings have been engineered considering latest industry standards as our starting point of improvement, the result is a more rugged, robust and strengthened product suitable for the most demanding applications such as modulating and offshore heavy duty services. Our actuators generate high torque outputs at a more cost effective price to our clients.

ProControl actuators are made completely from fabricated carbon steel.



COMPANY CERTIFICATIONS

Every aspect of our company's activities complies with **ISO 9001:2008** certified by Det Norske Veritas, no: 65458-2009-AQ-ITA-SINCERT, **ISO 14001:2004** certified by TÜV Rheinland, no: 01 104 1419947, **BS OHSAS 18001:2007** certified by TÜV Rheinland, no: 01 113 1419947

ProControl range of products holds the following international accreditations:

SIL (Certified by RWTÜV), TR-CU.

ProControl actuators are also in accordance with European directive 94/9/EC art.8.1.b.II group II category 2 - ATEX, -and the European Pressure Equipment directive PED 97/23/EC.



Scotch Yoke Mechanism SPS & SPD Series

The scotch yoke mechanism is precisely positioned inside a perfectly sealed housing which protects it against corrosion in the most adverse environments.

The housing also encompasses a stem thrust support device suitable to withstand the transversal forces generated during rotation and to ensure the proper alignment of the piston rod with the sliding blocks.

Low rotational friction is also ensured by means of oversized precise fitted bronze yoke shaft bushings which contribute to extend heavy duty working life span.

The scotch yoke mechanism transforms the linear movement (thrust) of the piston into a 90° rotation (torque).

ProControl actuators can be supplied with an inclined scotch yoke (canted) or a symmetric scotch yoke.

The symmetric scotch yoke gives very similar torques in both end positions and is normally used for plug valves, metal seated ball valves and control valves.

Symmetric scotch yoke is the most suitable yoke design for modulating service.

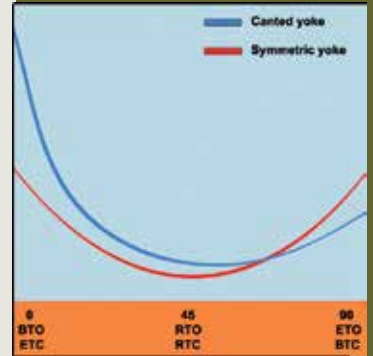

Symmetric & Canted Scotch Yoke

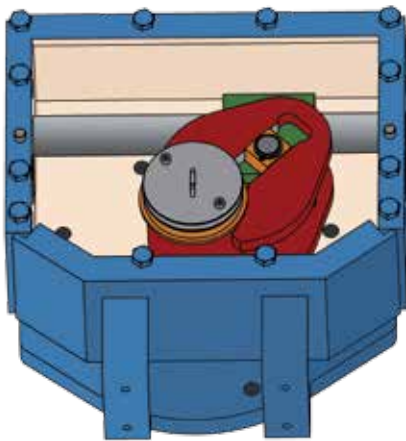

The **symmetric scotch yoke** is normally employed when the valve torque requirements are highest during the intermediate positions of the valves rotation (running), whilst lower at the beginning (valve unseating) and the end (valve reseating) of the valve 90° rotation. The symmetric scotch yoke mechanism is normally used for plug and some ball valve designs.

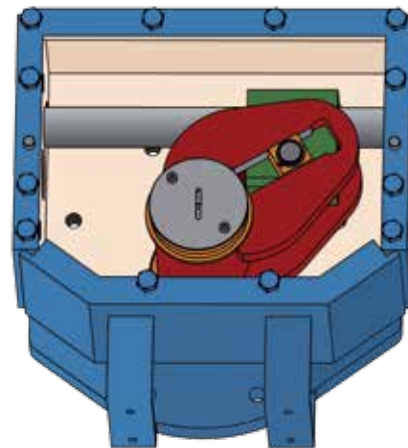

The **canted scotch yoke** is advantageous when the valve torque requirements are highest at the beginning (valve unseating) and the end (valve reseating) of the valve 90° rotation, whilst lowest during the intermediate position (running).

The canted scotch yoke mechanism covers most ball and butterfly valve torque requirements.



Construction & Materials

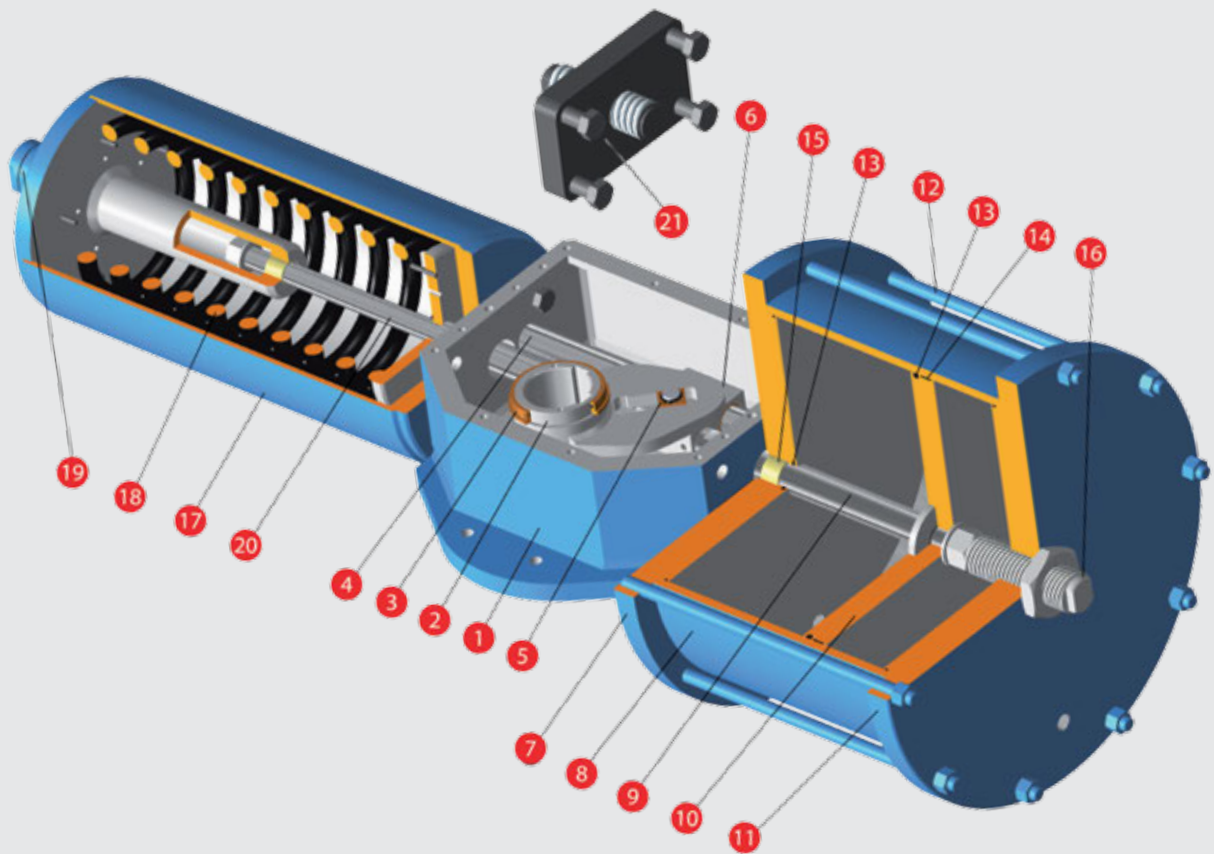

STANDARD MATERIALS FOR PROCONTROL SPD & SPS SERIES ACTUATORS

N°	DESCRIPTION	STD Material	ASTM equivalent	PED Material	ASTM equivalent
1	Housing	S235JR UNI EN 10025	A 283 grade D	S235JR UNI EN 10025	A 283 grade D
2	Yoke	S355 J2+N UNI EN 10025	A 588 grade A	S355 J2+N UNI EN 10025	A 588 grade A
3	Yoke bushing	G-CuSn12 UNI 7013	B 427 C90800	G-CuSn12 UNI 7013	B 427 C90800
4	Transversal thrust bar	42CrMo4 UNI 7845	A 193 B7	42CrMo4 UNI 7845	A 193 B7
5	Sliding block	G-CuAl11Fe4 UNI 5274	B 148 - 9D955	G-CuAl11Fe4 UNI 5274	B 148 - 9D955
6	Guide block	S275 JR EN 10025	A 529 grade 42	S275 JR EN 10025	A 529 grade 42
7	Cylinder head flange	S355 J2+N UNI EN 10025	A 570 grade 50	P355NL2 UNI EN10028-3	A 266 grade 1
8	Cylinder tube	355 EN10297-1	A 588 grade A	P355NL2 UNI EN10028-3 *	ASTM A333 grade 6
9	Piston rod	42CrMoS4 B UNI 10277-5	A 193 B7	42CrMoS4 B UNI 10277-5 *	A193 B7
10	Piston	S355 J2+N UNI EN 10025	A 570 grade 50	P355NL2 UNI EN10028-3	A 266 grade 1
11	End flange	S355 J2+N UNI EN 10025	A 570 grade 50	P355NL2 UNI EN10028-3	A 266 grade 1
12	Tie rod	ASTM A320 L7	ASTM A320 L7	ASTM A320 L7	ASTM A320 L7
13	O-ring	NBR	NBR	NBR	NBR
14	Piston guide ring	PTFE charged graphite	PTFE charged graphite	PTFE charged graphite	PTFE charged graphite
15	Rod bushing	Steel + bronze + PTFE	Steel + bronze + PTFE	Steel + bronze + PTFE	Steel + bronze + PTFE
16	Stop setting screw	ASTM A320 L7	ASTM A320 L7	ASTM A320 L7	ASTM A320 L7
17	Spring cartridge <i>SPS only</i>	S355 J2+N UNI EN 10025	A 570 grade 50	S355 J2+N UNI EN 10025	A 570 grade 50
18	Spring <i>SPS only</i>	60SiCr8 UNI 3545	A 519	60SiCr8 UNI 3545	A 519
19	Stop setting screw	ASTM A320 L7	ASTM A320 L7	ASTM A320 L7	ASTM A320 L7
20	Spring shaft <i>SPS only</i>	42CrMoS4 UNI 10277-5	A 193 B7	42CrMoS4 UNI 10277-5	A 193 B7
21	Closure flange <i>SPD only</i>	S355 J2+N UNI EN 10025	A 570 grade 40	S355 J2+N UNI EN 10025	A 570 grade 40

NOTE: - The scotch yoke housing is the same in canted & symmetric configuration - Seal material can change for high or low temperature application (NBR/VITON/FLUOROSILICONE)
*** WITH IMPACT TEST CERTIFICATE**

Modular Design Construction

ProControl scotch yoke actuators all share a common construction philosophy known as modularity, which is achieved by utilizing a consistent engineering design throughout our complete range. Our current range of scotch yoke actuators consists of various center body sizes. The center bodies have been designed to accommodate the widest variety of pneumatic and hydraulic power cylinders together with the widest variety of spring containers. The power cylinders can be assembled to either or both sides of the center body. The spring containers can be assembled onto either side of the center body thus allowing for the fail open or fail close emergency operation. The manual override can be assembled onto either side of the centre body our modular construction and stocking availability enables us to meet short deliveries.

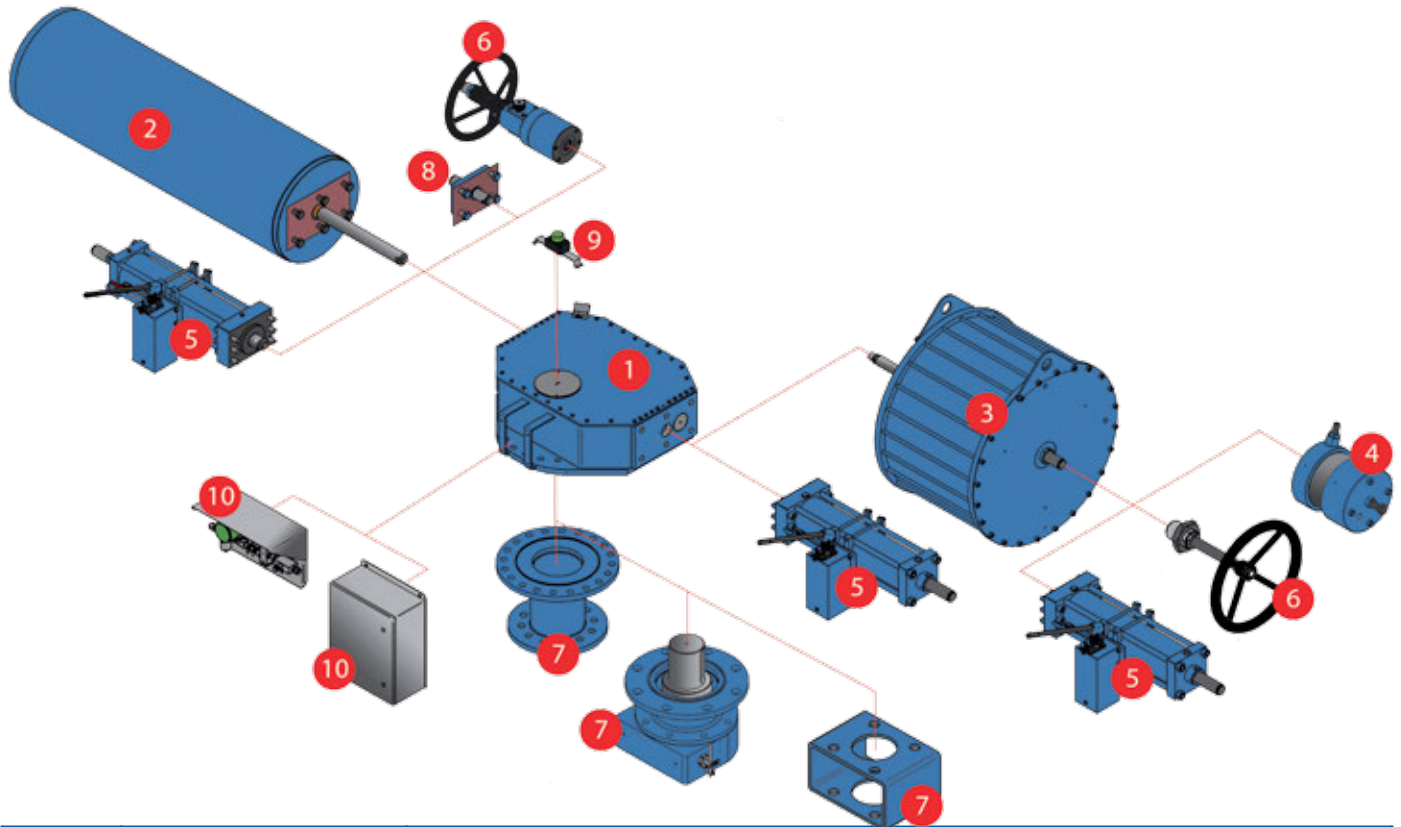

ITEM	DESCRIPTION	NOTES
1	Scotch yoke mechanism	- Symmetric or canted type - 10 main center body sizes
2	Spring container	- Several spring containers available
3	Pneumatic cylinder	- Widest variety of cylinders available
4	Integral quick exhaust & damper	- Suitable to achieve very short stroking times and dampen the last degrees of the stroke
5	Hydraulic cylinder	- Widest variety of cylinders available - Implemented with hydraulic pump for manual override HP
6	Jack screw with handwheel	- HW manual override suitable for smaller actuators
7	Mounting bracket	- Open or closed type (optional) - Pro Lock device for mechanical partial stroke test also available
8	Closure plate	- For double acting actuators
9	Limit switch box	- Implementable or interchangeable with accessories such as positioner, signaling limit switches, position transmitters, etc.
10	Control system	- Panel or cabinet version - Customized design

Design Features

MECHANICAL TRAVEL STOP

Two adjustable mechanical travel stops to allow the fine adjustment of the valve angular stroke by means of stop screws, which are located one into the end flange of the spring container and the other into the end flange of the pneumatic cylinder, or on the mechanical manual hand wheel override, or on the end flange of the hydraulic manual override cylinder, depending on the actuator version.

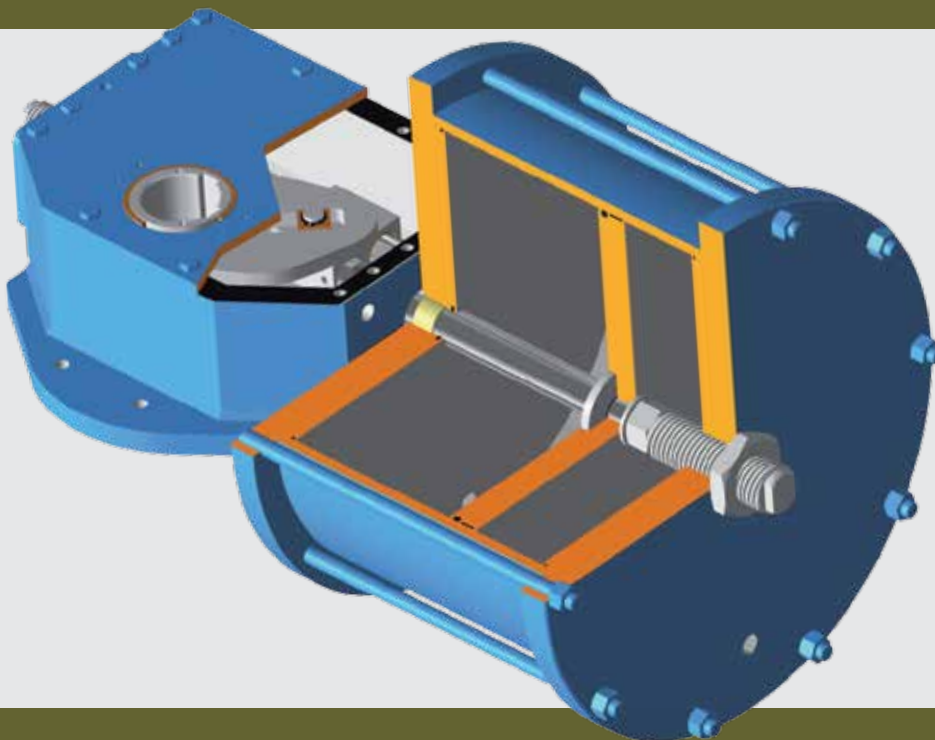
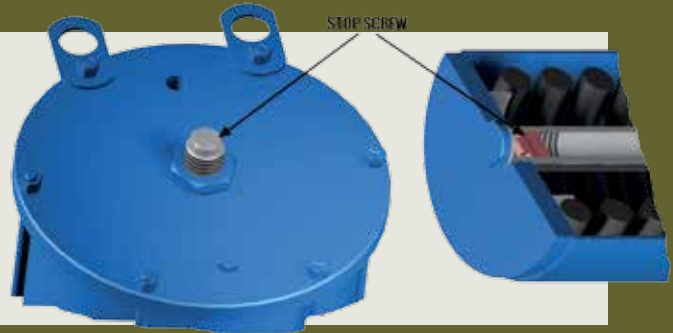

THE PNEUMATIC CYLINDER

The pneumatic cylinder is manufactured from carbon steel. The cylinder tube is machine polished and electroless nickel plated internally in order to reduce surface roughness to a minimum value and to provide highest protection against corrosion and low maintenance. The piston is made of carbon steel and sealing is performed by means of a floating o-ring design and guided internally by a sliding ring in Teflon graphite. The dynamic seals of the pneumatic cylinder are specifically designed to allow the use of the actuator without additional lubrication.

FULLY SEALED VISUAL INDICATOR

SPECIAL SLIDING BLOCKS

High performance sliding blocks allow to reduce friction and wear between moving parts.

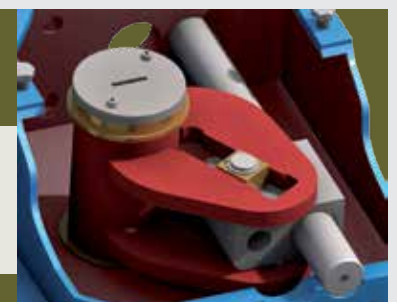
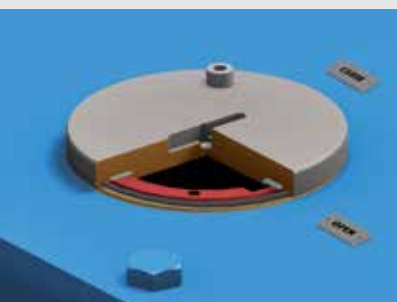

PROCONTROL STANDARD KEYWAYS

The assembly position of the actuator must be in accordance with plant requirements (which normally cylinder axis parallel to the pipeline or in some cases where space is limited assembly may be perpendicular to the pipeline axis) and with the valve model.

ProControl actuators have as a standard 2 90° keyways machined into the yoke which combined with our valve adaptation kit allows four 90° actuator positions.

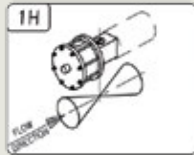

"1H" IS THE STANDARD MOUNTING FOR FAIL OPEN PROCONTROL ACTUATOR

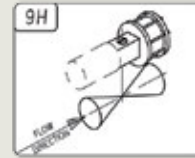

"9H" IS THE STANDARD MOUNTING FOR FAIL CLOSE AND DOUBLE ACTING PROCONTROL ACTUATOR

Pro Lock Mechanical Partial Stroke Device

DESCRIPTION

ProControl designed a **Carbon Steel** epoxy coated **declutchable mechanical blocking device** which when engaged allows a pre-set valve / actuator **partial stroke** of approximate 20°.

The **Pro Lock mechanical blocking device** is located between the valve and the actuator and consists of a **heavy duty steel** self-contained unit, therefore it does not stress the valves shaft nor the actuators yoke.

It is **pad lockable** and can also be fitted with a **limit switch** if required by the client to signal that it is engaged. During normal operation the **device is passive** and **will allow the valve to ESD on demand**.

When a partial stroke test is required, the device is **"engaged"** and the **ESD valve** will only travel to the specified percentage of stroke.

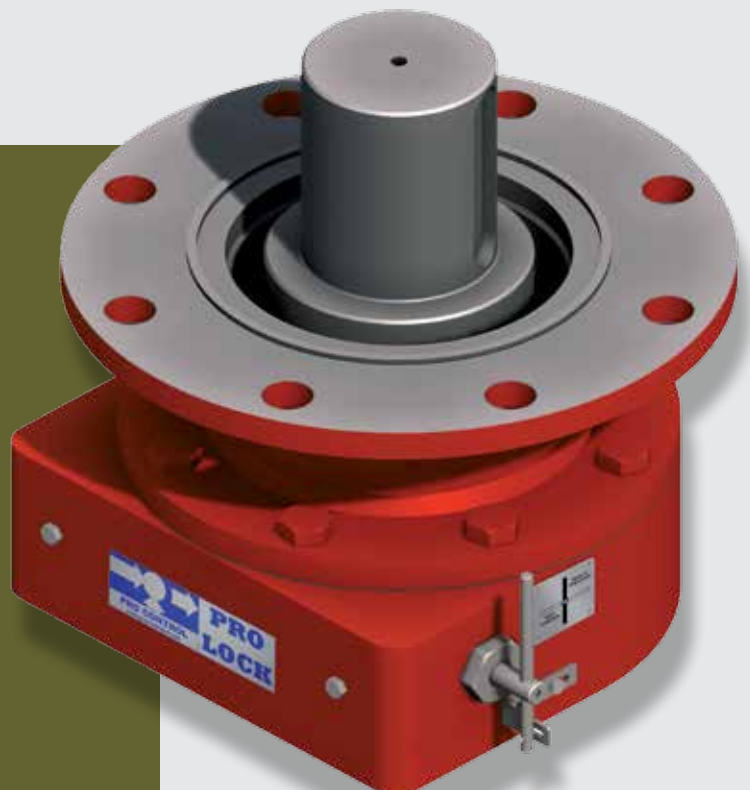

SPS Fast & Ultra Fast actuators

ULTRA FAST SPS

ProControl has engineered a special design which is fitted to all single acting spring return actuators consisting of an **INTEGRAL QUICK EXHAUST VALVE DAMPER**.

This engineered product allows for fast and ultra-fast fail action stroking times.

The product has been specifically designed for our pneumatic **SPS series** scotch yoke actuators.

The principal of operation consists in discharging a large volume of stored air by spring stroke in the shortest possible time (**Integral Quick Exhaust Valve**), but at the same time it is essential to provide a cushioned or dampened end of stroke (**valve seating**) in order to avoid potential damage to the valves drive train and seats as well as the actuators end of stroke travel stops and related components from high velocity impact (**Damper system**).



The **INTEGRAL QUICK EXHAUST VALVE DAMPER** consists primarily of a 2 way 2 position custom engineered piloted integral high flow discharge valve, complete with an integral end of stroke damper system. The quick discharge of air from the pneumatic cylinder occurs for approximately **80-85%** of the valve actuators stroke, and the last 15-20° of rotation generally considered for reseating the valve is dampened.

Our design allows for an adjustable intervention of the speed of dampening since the device is fitted with an internal by-pass valve complete with an integral dedicated flow regulator.

Our purpose built and certified product also allows for assembly of manual overrides in both jack screw and hydraulic hand pump execution as well as conveyed air discharge in the event of special orientation requirements or assembly of passive fire protection systems.

Due to the variety of applications our **INTEGRAL QUICK EXHAUST VALVE DAMPER** is available in different materials of construction such as : **aluminum alloy or AISI 316**.

Speed Curve Diagram

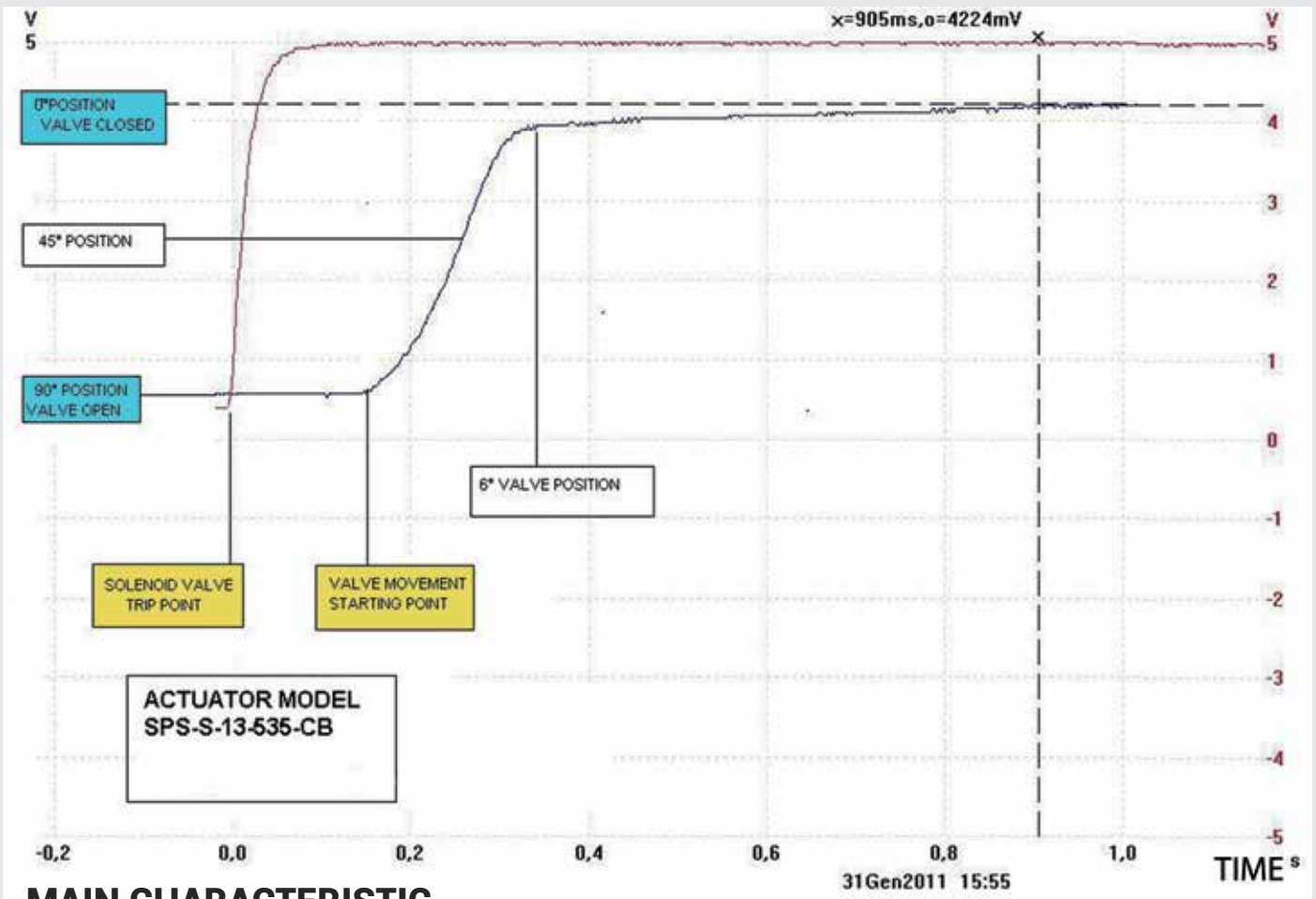

MAIN CHARACTERISTIC

- **Operating time** 0.1 to 2 sec. depending on the valve and actuator size and supply pressure
- Available for all size of actuators
- **Operating pressure** from 10 to 250 barg
- **Actuated valve:** ball, butterfly, special

Our Integral quick exhaust damper system allows a variety of features and benefits such as :

- Use of actuated valves with fast and ultra-fast fail safe stroking times
- Special damping system in order to avoid serious damage to the valve drive train and actuator
- Combined On-Off and Modulating service (2 applications with one single actuated valve with significant cost saving for the customer)
- High level of reliability, where actuators and integral quick exhaust valves are SIL 3 certified by TUV
- HIPPS application
- Possibility to provide redundancy for critical control components like the Integral quick exhaust valve to further increase the systems reliability.
- Our design also permits partial stroke testing via the integrated by-pass system design thus avoiding a full system shutdown during field testing of more traditional means of fast closure.
- Heavy duty construction for high cycle fast acting service.
- Special coatings and MOC for off-shore or corrosive environments
- All actuators are factory set to clients requirements and tested with speed recording and supplied with (angular stroke vs. time graphs).
- ProControl is also available to carry out tests and assist client once the actuator is assembled onto the valve.



LOCATION



A nighttime photograph of a medieval castle. The castle features a prominent clock tower with a white face and a dark roof. The battlements are illuminated, and the surrounding buildings are lit up, creating a warm glow against the dark sky.

ProControl

is located at the foot hills of an ancient medieval castel built in the early XII century.

With excellent road accessibility connections from the A1 motorway
Closest railway stations are
Fiorenzuola, Fidenza and Piacenza.

Closest airports are

Milan Linate (1 hour),
Milan Malpensa (1 & 1/2 hours),
Bergamo (1 hour),
Bologna (1 hour) or
Parma (45 minutes).

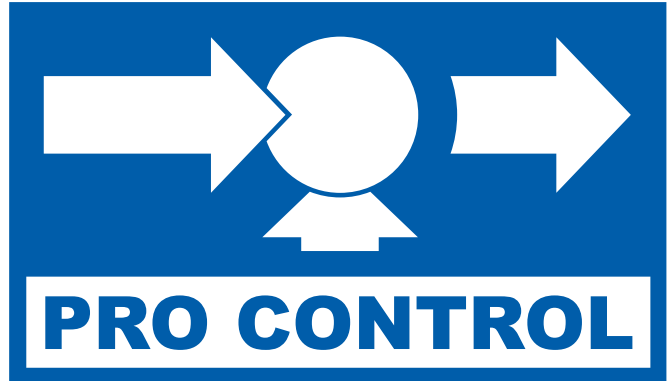

VALVE ACTUATION & CONTROL



**Valve
& Automation**

Total Valve & Control Solutions®

VEREENIGING

Tel: 011 397 2833

Fax: 011 397 4700

DURBAN

Tel: 031 579 2593

Fax: 031 579 2562

South Africa:

0861 103 103

E-mail: sales@valve.co.za

Exports:

africaexports@valve.co.za

www.valve.co.za



SCAN ME